

GEMÜ B54

Motorized ball valve



Features

- Checked delta ferrite material < 3% (1.4435)
- Material certificates for media wetted components
- Media wetted surfaces according to ASME SF5 (Ra 0.51 µm)
- Suitable for vacuum applications
- Optionally available with cavity-filled seat
- Butt weld spigots in extended orbital welding design
- Ball valve body, assembled free of oil/grease

Description

The GEMÜ B54 3-piece 2/2-way metal ball valve is motorized. Various on/off or control actuators are available. The 1.4435 stainless steel alloy material composition used for the ball valve body (compliant with 316L) with a low delta ferrite proportion of < 3% is particularly suited to applications in the supply sector for the pharmaceutical, foodstuffs processing and biotechnology (such as water treatment and sterile steam generation) industries. Only those plastics which are compliant with FDA, USP Class VI and Regulation (EU) No.10/2011 are used for the seals.

Technical specifications

- **Media temperature:** 14 to 428 °F
- **Ambient temperature:** -4 to 140 °F
- **Operating pressure:** 0 to 914 psi
- **Body configurations:** 2/2-way body
- **Connection type:** Clamp | Spigot
- **Connection standards:** ASME | DIN | ISO | SMS
- **Body materials:** 1.4435 (316L), investment casting material
- **Seal materials:** PTFE
- **Supply voltage:** 12 V AC, 50/60 Hz | 12 V DC | 24 - 240 V AC/DC | 24 V AC, 50/60 Hz | 24 V DC
- **Operating time 90°:** 4 to 58 s
- **Protection class:** IP 65. IP 67. IP 68

Technical data depends on the respective configuration



further information
webcode: GW-B54



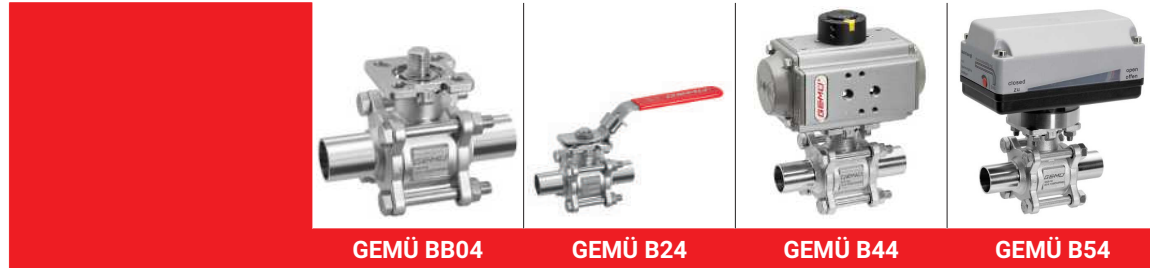

Product line



	GEMÜ BB04	GEMÜ B24	GEMÜ B44	GEMÜ B54
Operation				
With bare shaft	●	-	-	-
Manual	-	●	-	-
pneumatic	-	-	●	-
Motorized	-	-	-	●
Nominal sizes	1/4" (DN 8) to 4" (DN 100)	1/4" (DN 8) to 4" (DN 100)	1/4" (DN 8) to 4" (DN 100)	1/4" (DN 8) to 4" (DN 100)
Media temperature	14 to 428 °F	14 to 428 °F	14 to 428 °F	14 to 428 °F
Operating pressure	0 to 914 psi	0 to 914 psi	0 to 914 psi	0 to 914 psi
Connection types				
Clamp	●	●	●	●
Spigot	●	●	●	●

GEMÜ, J+J motorized actuators

			
	GEMÜ 9428	GEMÜ 9468	GEMÜ J4C
Manufacturer	GEMÜ	GEMÜ	J+J
Manufacturer type	9428	9468	J4C
Torques	6 to 55 Nm	70 to 200 Nm	20 to 300 Nm
Duty cycle	100 %	30 % (ON/OFF actuator) 50 % (control actuator)	75 %
Heating	No	No	Yes
Voltage			
12 V AC, 50/60 Hz	●	-	-
12 V DC	●	-	●
24 - 240 V AC/DC	-	-	●
24 V AC, 50/60 Hz	●	-	-
24 V DC	●	●	-
Protection class	IP 65, IP 67	IP 65	IP 67
Ambient temperature	14 to 140 °F	14 to 140 °F	-4 to 158 °F
Housing materials			
ABS	-	●	-
Aluminium	-	●	-
Polyamide (PA6)	-	-	●
PP	●	-	-
Versions			
Limit switches	●	●	●
ON/OFF actuator	●	●	-
Optional battery pack	-	-	●
Optional positioner	-	-	●
Optional positioning actuator	-	●	●
Optional potentiometer	-	●	-
Optionally 3 positions	-	-	●

Comparison of areas of application for GEMÜ, J+J actuators



	GEMÜ 9428	GEMÜ 9468	GEMÜ J4C
Range of functions			
Use in non-aggressive environment (up to C3)	●	●	●
Use in aggressive environment (C5)	●	●	●
Use in protected outdoor areas	●	●	●
Use in unprotected outdoor areas	●	●	●
Applications with many/frequent cycle duties	●	●	●
Fail-safe option	●	●	●
Positioning application	●	●	●
Industrial sectors			
Chemical processes	●	●	●
Surface finishing	●	●	●
Water treatment	●	●	●
Mechanical engineering	●	●	●
Power generation and environmental systems	●	●	●
Food processing technology	●	●	●
Semiconductor	●	●	●
Medical systems	●	●	●
Pharmaceutical industry	●	●	●

Product description

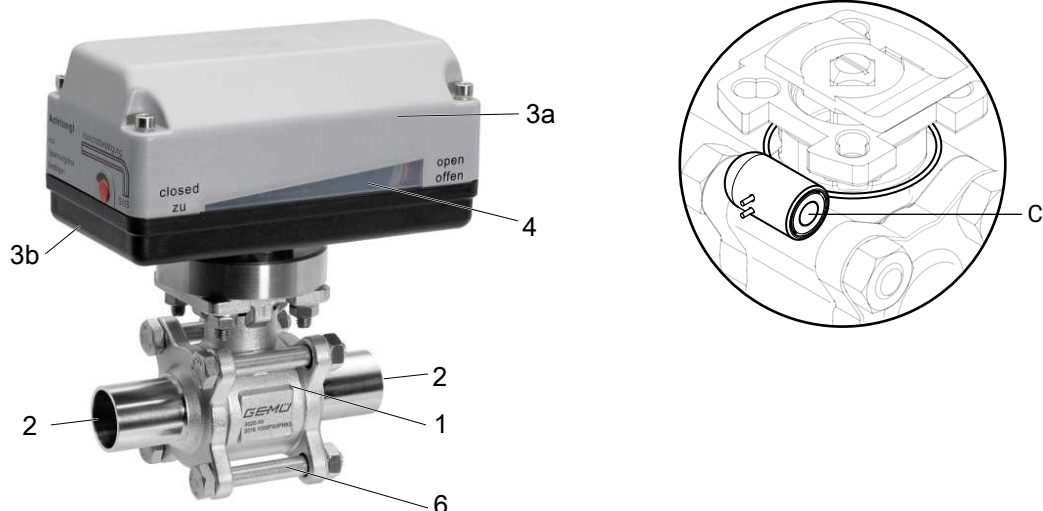

Item	Name	Materials
1	Ball valve body	ASTM A351/1.4435 (316L)
2	Pipe connections	ASTM A351/1.4435 (316L)
3a	Actuator housing cover Actuator version 1006,1015 Actuator version 3035, 3055 Actuator version 4100, 4200	PPO (10% glass fibre reinforced) PP (30% glass fibre reinforced) Aluminium
3b	Actuator housing base Actuator version 1006, 1015, 3035, 3055 Actuator version 4100, 4200	PP (30% glass fibre reinforced) Aluminium
4	Optical position indicator, position indicator	PP-R natural
6	Bolt	A2 70
	Seals	PTFE
C	CONEXO RFID chip (see "GEMÜ CONEXO", page 37)	

Cavity-filled PTFE seal (Code 5H)



- The cavity-filled seal, which is made of PTFE, is specially designed to reduce excess volumes in the ball cavity.
- Media that remains in the valve's dead spaces is unwanted during food production, for example, and may decontaminate this.
- These deposits accumulate and contaminate the entire process. Thanks to this special seal variant, the volume in the ball cavity is reduced to a minimum.

Application

- Water treatment
- Steam processing
- CIP/SIP
- Waste water treatment
- Storage and distribution
- Drying

The spindle seal system

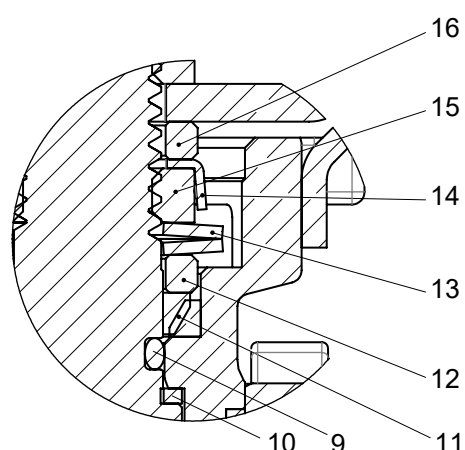

Item	Name	Material
9	O-ring	Viton
10	Seal	PTFE
11	V-ring	PTFE
12	Stainless steel sleeve	SS304-1.4301
13	Spring washer	SS304-1.4301
14	Cap	SS304-1.4301
15	Spindle nut	A2 70
16	Washer	SS304-1.4301

Long service life due to double spindle seal

- Conical spindle seal:

The seal **10** arranged at an angle of 45° effectively prevents the leakage of medium when operating the spindle

- Pretensioned self-adjusting spindle seal:

The spindle packing consists of several V-rings **11**, a spring washer **13** and a stainless steel sleeve **12**. The spring washer **13** is pretensioned via the spindle nut **14**. The pretension force is distributed to the V-rings **11** via the stainless steel sleeve **12**, thereby preventing the leakage of media. The pretension provides low maintenance and reliable spindle sealing even after a long service life.

Availability

DN	NPS	Connection type code ¹⁾					
		17	37	59	60	80	93
8	1/4"	-	-	-	X	-	-
10	3/8"	X	-	-	X	-	-
15	1/2"	X	-	X	X	X	X
20	3/4"	X	X	X	X	X	X
25	1"	X	X	X	X	X	X
32	1¼"	X	-	-	X	-	-
40	1½"	X	X	X	X	X	X
50	2"	X	X	X	X	X	X
65	2½"	X	X	X	X	X	X
80	3"	X	X	X	X	X	X
100	4"	X	X	X	X	X	X

1) **Connection type**

Code 17: Spigot EN 10357 series A/DIN 11866 series A formerly DIN 11850 series 2

Code 37: Spigot SMS 3008

Code 59: Spigot ASME BPE/DIN EN 10357 series C (from 2022 edition)/DIN 11866 series C

Code 60: Spigot ISO 1127/DIN EN 10357 series C (2014 edition)/DIN 11866 series B

Code 80: Clamp ASME BPE

Code 93: On one side, clamp ASME BPE corresponding to code 80, on the other side, butt weld spigot code 59, for pipe ASME BPE

Actuator assignment

GEMÜ actuator

GEMÜ type	Actuator version (code)	Control module (code) ¹⁾	Voltage/Frequency			
			12 V DC (code B1)	12 V AC (code B4)	24 V DC (code C1)	24 V AC (code C4)
9428	1006	A0, AE	X	X	X	X
	1015		X	-	X	-
	3035		-	-	X	-
	3055		-	-	X	-
9468	4100	00, 0E, 0P	-	-	X	-
	4200		-	-	X	-

1) Control module

Code 00: ON/OFF actuator, relay, not reversible

Code 0E: ON/OFF actuator, two additional potential-free limit switches, relay, not reversible

Code 0P: ON/OFF actuator, potentiometer output, relay, not reversible

Code A0: ON/OFF actuator

Code AE: ON/OFF actuator, two additional potential-free limit switches, Class A (EN15714-2)

PTFE (FDA certification), cavity filled (Code 5H)

DN	NPS	Actuator version (code)					
		1006	1015	3035	3055	4100	4200
8	1/4"	X	-	-	-	-	-
10	3/8"	X	-	-	-	-	-
15	1/2"	-	X	-	-	-	-
20	3/4"	-	X	-	-	-	-
25	1"	-	-	X	-	-	-
32	1¼"	-	-	X	-	-	-
40	1½"	-	-	-	X	-	-
50	2"	-	-	-	X	-	-
65	2½"	-	-	-	-	X	-
80	3"	-	-	-	-	X	-
100	4"	-	-	-	-	-	X

Seal material PTFE (FDA certification) (Code 5T)

DN	NPS	Actuator version (code)				
		1006	1015	3035	4100	4200
8	1/4"	X	-	-	-	-
10	3/8"	X	-	-	-	-
15	1/2"	-	X	-	-	-
20	3/4"	-	X	-	-	-
25	1"	-	X	-	-	-
32	1¼"	-	X	-	-	-
40	1½"	-	-	X	-	-
50	2"	-	-	X	-	-
65	2½"	-	-	-	X	-
80	3"	-	-	-	X	-
100	4"	-	-	-	-	X

J+J actuator

J+J - Voltage/Frequency

Voltage/Fre- quency	Code	Actuator version (code)				
		J4C20	J4C35	J4C55	J4C14	J4C30
24 – 240 V AC/ DC	U5	X	X	X	X	X

J+J - Control module

Control module	Code ¹⁾	Actuator version (code)				
		J4C20	J4C35	J4C55	J4C14	J4C30
Open/close	A3	X	X	X	X	X
	AE	X	X	X	X	X
	AE1	X	X	X	X	X
	AE2	X	X	X	X	X
	AP	X	X	X	X	X
	AP1	X	X	X	-	-
Positioner	E1	X	X	X	X	X
	E11	X	X	X	-	-
	E2	X	X	X	X	X
	E22	X	X	X	-	-

1) Control module

Code A3: ON/OFF actuator, three-position actuator, additional potential-free limit switches

Code AE: ON/OFF actuator, two additional potential-free limit switches, Class A (EN15714-2)

Code AE1: ON/OFF actuator, two additional potential-free limit switches, BSR battery pack (NC)

Code AE2: ON/OFF actuator, two additional potential-free limit switches, BSR battery pack (NO)

Code AP: ON/OFF actuator, potentiometer output, Class A (EN15714-2)

Code AP1: ON/OFF actuator, two additional potential-free limit switches, potentiometer output 5 kOhm, FailSafe battery pack (NC), preferred direction is adjustable

Code E1: Control actuator, external set value 0–10 VDC

Code E11: DPS positioner, external set value 0–10 V, BSR battery pack (NC)

Code E2: Control actuator, external set value 0/4–20 mA

Code E22: DPS positioner, external set value 4–20 mA, BSR battery pack (NO)

PTFE (FDA certification), cavity filled (Code 5H)

DN	NPS	Actuator version (code)			
		J4C20	J4C55	J4C14	J4C30
8	1/4"	X	-	-	-
10	3/8"	X	-	-	-
15	1/2"	X	-	-	-
20	3/4"	X	-	-	-
25	1"	X	-	-	-
32	1¼"	X	-	-	-
40	1½"	-	X	-	-
50	2"	-	X	-	-
65	2½"	-	-	X	-
80	3"	-	-	X	-
100	4"	-	-	-	X

Seal material PTFE (FDA certification) (Code 5T)

DN	NPS	Actuator version (code)		
		J4C20	J4C35	J4C14
8	1/4"	X	-	-
10	3/8"	X	-	-
15	1/2"	X	-	-
20	3/4"	X	-	-
25	1"	X	-	-
32	1¼"	X	-	-
40	1½"	-	X	-
50	2"	-	X	-
65	2½"	-	-	X
80	3"	-	-	X
100	4"	-	-	X

Order data

Ball valve with GEMÜ 9428, 9468 actuator

The order data provide an overview of standard configurations.

Please check the availability before ordering. Other configurations available on request.

Products ordered with **bold marked ordering options** are so-called preferred series. Depending on the nominal size, these are available more quickly.

Order codes

1 Type	Code
Ball valve, metal, electrically operated, three-piece body, sanitary, checked delta ferrite material and media wetted surfaces according to ASME SF5, ISO 5211, top flange, lockable hand lever, low-maintenance spindle seal and blow-out proof shaft, with antistatic unit	B54

2 DN	Code
DN 8	8
DN 10	10
DN 15	15
DN 20	20
DN 25	25
DN 32	32
DN 40	40
DN 50	50
DN 65	65
DN 80	80
DN 100	100

3 Body/ball configuration	Code
2/2-way body	D

4 Connection type	Code
Spigot EN 10357 series A/DIN 11866 series A formerly DIN 11850 series 2	17
Spigot SMS 3008	37
Spigot ASME BPE/DIN EN 10357 series C (from 2022 edition)/DIN 11866 series C	59
Spigot ISO 1127/DIN EN 10357 series C (2014 edition)/DIN 11866 series B	60
Clamp ASME BPE	80
On one side, clamp ASME BPE corresponding to code 80, on the other side, butt weld spigot code 59, for pipe ASME BPE	93

5 Ball valve material	Code
1.4435/ASTM A351, low ferrite <3% (equivalent to 316L Δ Fe<3%) (body, connection, ball), 1.4409/SS316L (spindle)	C3

6 Seal material	Code
PTFE (FDA certification)	5T
PTFE (FDA certification), cavity filled	5H

7 Voltage/Frequency	Code
12 VDC	B1
12 V, 50/60 Hz	B4
24 VDC	C1
24 V, 50/60 Hz	C4

8 Control module	Code
ON/OFF actuator, relay, not reversible	00
ON/OFF actuator, two additional potential-free limit switches, relay, not reversible	0E
ON/OFF actuator, potentiometer output, relay, not reversible	0P
ON/OFF actuator	A0
ON/OFF actuator, two additional potential-free limit switches, Class A (EN15714-2)	AE

9 Actuator version	Code
Actuator, motorized, operating time 4 s, torque 6 Nm, GEMUE, size 1 supply voltage B1, C1, B4, C4	1006
Actuator, motorized, operating time 11 s, torque 15 Nm, GEMUE, size 1 supply voltage B1, C1	1015
Actuator, motorized, operating time 15 s, torque 35 Nm, GEMUE, size 3, supply voltage C1	3035
Actuator, motorized, operating time 15 s, torque 55 Nm, GEMUE, size 3, supply voltage C1	3055
Actuator, motorized, operating time 20 s, torque 100 Nm, GEMUE, size 4, supply voltage C1	4100
Actuator, motorized, operating time 16 s, torque 200 Nm, GEMUE, size 4, supply voltage C1	4200

10 Type of design	Code
Standard	
Ra \leq 0.4 μ m (15 μ in.) for media wetted surfaces *), in accordance with DIN 11866 HE4, electropolished internal/external, *) for inner pipe diameter \leq 6 mm, in spigot Ra \leq 0.8 μ m	1537

10 Type of design	Code
K-NO SF5, K-NO 5227, SF5 – Ra max. 0.51 µm (20 µin.) electropolished internal/external, 5227 – thermal separation by mounting kit	7138
K-NO SF5, K-NO 0101, SF5 – Ra max. 0.51 µm (20 µin.) electropolished internal/external, 0101 – media wetted area cleaned to ensure suitability for paint applications	7140
K-NO SF5, K-NO 0104, SF5 – Ra max. 0.51 µm (20 µin.) electropolished internal/external, 0104 – media wetted parts cleaned for high purity media and packed in plastic bag	7141

10 Type of design	Code
K-NO SF5, K-NO 0107, SF5 – Ra max. 0.51 µm (20 µin.) electropolished internal/external, 0107 – valve free of oil and grease, media wetted area cleaned	7142
Ra max. 0.38 µm (15 µin.) for media wetted surfaces, in accordance with ASME BPE SF4, electropolished internal/external	SF4
Ra max. 0.51 µm (20 µin.) for media wetted surfaces, in accordance with ASME BPE SF5, electropolished internal/external	SF5
11 CONEXO	Code
Without	
Integrated RFID chip for electronic identification and traceability	C

Order example

Order option	Code	Description
1 Type	B54	Ball valve, metal, electrically operated, three-piece body, sanitary, checked delta ferrite material and media wetted surfaces according to ASME SF5, ISO 5211, top flange, lockable hand lever, low-maintenance spindle seal and blow-out proof shaft, with antistatic unit
2 DN	15	DN 15
3 Body/ball configuration	D	2/2-way body
4 Connection type	59	Spigot ASME BPE/DIN EN 10357 series C (from 2022 edition)/DIN 11866 series C
5 Ball valve material	C3	1.4435/ASTM A351, low ferrite <3% (equivalent to 316L Δ Fe<3%) (body, connection, ball), 1.4409/SS316L (spindle)
6 Seal material	5T	PTFE (FDA certification)
7 Voltage/Frequency	C1	24 VDC
8 Control module	A0	ON/OFF actuator
9 Actuator version	1015	Actuator, motorized, operating time 11 s, torque 15 Nm, GEMUE, size 1 supply voltage B1, C1
10 Type of design		Standard
11 CONEXO		Without

Ball valve with J+J actuator

The order data provide an overview of standard configurations.

Please check the availability before ordering. Other configurations available on request.

Products ordered with **bold marked ordering options** are so-called preferred series. Depending on the nominal size, these are available more quickly.

Order codes

1 Type	Code
Ball valve, metal, electrically operated, three-piece body, sanitary, checked delta ferrite material and media wetted surfaces according to ASME SF5, ISO 5211, top flange, lockable hand lever, low-maintenance spindle seal and blow-out proof shaft, with antistatic unit	B54

2 DN	Code
DN 8	8
DN 10	10
DN 15	15
DN 20	20
DN 25	25
DN 32	32
DN 40	40
DN 50	50
DN 65	65
DN 80	80
DN 100	100

3 Body/ball configuration	Code
2/2-way body	D

4 Connection type	Code
Spigot EN 10357 series A/DIN 11866 series A formerly DIN 11850 series 2	17
Spigot SMS 3008	37
Spigot ASME BPE/DIN EN 10357 series C (from 2022 edition)/DIN 11866 series C	59
Spigot ISO 1127/DIN EN 10357 series C (2014 edition)/DIN 11866 series B	60
Clamp ASME BPE	80
On one side, clamp ASME BPE corresponding to code 80, on the other side, butt weld spigot code 59, for pipe ASME BPE	93

5 Ball valve material	Code
1.4435/ASTM A351, low ferrite <3% (equivalent to 316L Δ Fe<3%) (body, connection, ball), 1.4409/SS316L (spindle)	C3

6 Seal material	Code
PTFE (FDA certification)	5T
PTFE (FDA certification), cavity filled	5H

7 Voltage/Frequency	Code
24 V–240 V AC/DC for model 20, 35, 55, 85, 140, 300	U5

8 Control module	Code
ON/OFF actuator, three-position actuator, additional potential-free limit switches	A3
ON/OFF actuator, two additional potential-free limit switches, Class A (EN15714-2)	AE
ON/OFF actuator, two additional potential-free limit switches, BSR battery pack (NC)	AE1
ON/OFF actuator, two additional potential-free limit switches, BSR battery pack (NO)	AE2
ON/OFF actuator, potentiometer output, Class A (EN15714-2)	AP
ON/OFF actuator, two additional potential-free limit switches, potentiometer output 5 kOhm, FailSafe battery pack (NC), preferred direction is adjustable	AP1
Control actuator, external set value 0–10 VDC	E1
DPS positioner, external set value 0–10 V, BSR battery pack (NC)	E11
Control actuator, external set value 0/4–20 mA	E2
DPS positioner, external set value 4–20 mA, BSR battery pack (NO)	E22

9 Actuator version	Code
Actuator, motorized, operating time 9 s, torque 20 Nm, J+J, type J4, heating, IP67	J4C20
Actuator, motorized, operating time 9 s, torque 35 Nm, J+J, type J4, heating, IP67	J4C35
Actuator, motorized, operating time 13 s, torque 55 Nm, J+J, type J4, heating, IP67	J4C55
Actuator, motorized, operating time 34 s, torque 140 Nm, J+J, type J4, heating, IP67	J4C14
Actuator, motorized, operating time 58 s, torque 300 Nm, J+J, type J4, heating, IP67	J4C30

10 Type of design	Code
Standard	

10 Type of design	Code
Ra ≤ 0.4 μm (15 μin.) for media wetted surfaces *), in accordance with DIN 11866 HE4, electropolished internal/external, *) for inner pipe diameter ≤ 6 mm, in spigot Ra ≤ 0.8 μm	1537
K-NO SF5, K-NO 5227, SF5 – Ra max. 0.51 μm (20 μin.) electropolished internal/external, 5227 – thermal separation by mounting kit	7138
K-NO SF5, K-NO 0101, SF5 – Ra max. 0.51 μm (20 μin.) electropolished internal/external, 0101 – media wetted area cleaned to ensure suitability for paint applications	7140
K-NO SF5, K-NO 0104, SF5 – Ra max. 0.51 μm (20 μin.) electropolished internal/external, 0104 – media wetted parts cleaned for high purity media and packed in plastic bag	7141

10 Type of design	Code
K-NO SF5, K-NO 0107, SF5 – Ra max. 0.51 μm (20 μin.) electropolished internal/external, 0107 – valve free of oil and grease, media wetted area cleaned	7142
Ra max. 0.38 μm (15 μin.) for media wetted surfaces, in accordance with ASME BPE SF4, electropolished internal/external	SF4
Ra max. 0.51 μm (20 μin.) for media wetted surfaces, in accordance with ASME BPE SF5, electropolished internal/external	SF5

11 CONEXO	Code
Without	
Integrated RFID chip for electronic identification and traceability	C

Order example

Order option	Code	Description
1 Type	B54	Ball valve, metal, electrically operated, three-piece body, sanitary, checked delta ferrite material and media wetted surfaces according to ASME SF5, ISO 5211, top flange, lockable hand lever, low-maintenance spindle seal and blow-out proof shaft, with antistatic unit
2 DN	15	DN 15
3 Body/ball configuration	D	2/2-way body
4 Connection type	59	Spigot ASME BPE/DIN EN 10357 series C (from 2022 edition)/DIN 11866 series C
5 Ball valve material	C3	1.4435/ASTM A351, low ferrite <3% (equivalent to 316L Δ Fe<3%) (body, connection, ball), 1.4409/SS316L (spindle)
6 Seal material	5T	PTFE (FDA certification)
7 Voltage/Frequency	U5	24 V–240 V AC/DC for model 20, 35, 55, 85, 140, 300
8 Control module	AE	ON/OFF actuator, two additional potential-free limit switches, Class A (EN15714-2)
9 Actuator version	J4C20	Actuator, motorized, operating time 9 s, torque 20 Nm, J+J, type J4, heating, IP67
10 Type of design		Standard
11 CONEXO		Without

Ball valve technical data

Medium

Working medium: Corrosive, inert, gaseous and liquid media and steam which have no negative impact on the physical and chemical properties of the body and seal material.

Temperature with note

Media temperature: 14 – 428 °F
 For media temperatures > 212 °F, we recommend using a mounting kit with adapter between the ball valve and the actuator.

Ambient temperature: -4 – 140 °F

Storage temperature: 41 – 104 °F

Pressure

Operating pressure: 0 – 914 psi

Vacuum: Can be used up to a vacuum of 1.5 inhg (absolute)
 These values apply to room temperature and air. The values may deviate for other media and other temperatures.

Pressure/temperature diagram:

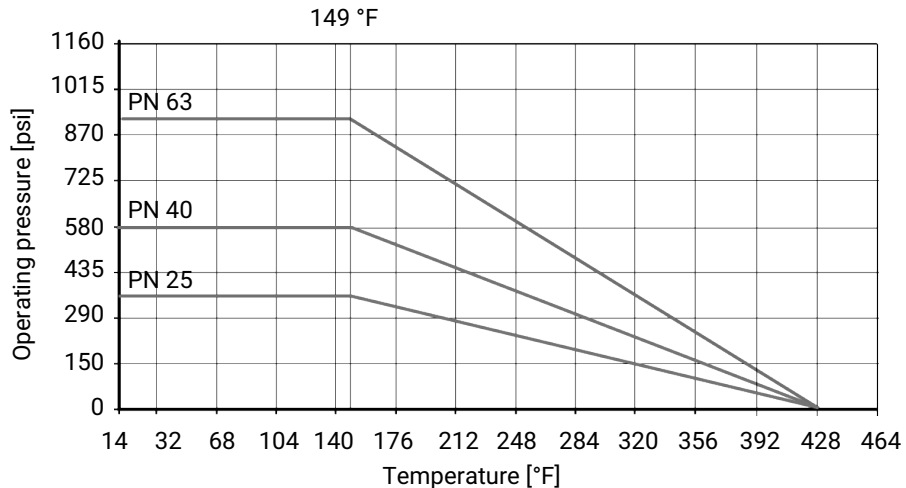

Pressure/temperature data in accordance with diagram refers to static operating conditions. Strongly fluctuating or fast-changing parameters can lead to a reduction of the service life. Special applications must be talked through with your technical contact person in advance.

Use the clamped union with the correct pressure rating for a safe and correct pipeline design. Pressure ratings of the clamp alone are generally higher, but do not take into account the fully clamped assembly with gasket

Leakage rate: Leakage rate according to ANSI FCI70 – B16.104
 Leakage rate according to EN 12266, 87 psi air, leakage rate A

Cv-values:	DN	NPS	Connection type (code)		
			17	37, 59, 80, 93	60
	8	1/4"	8.19	-	8.19
	10	3/8"	8.19	-	8.19
	15	1/2"	21.06	10.53	21.06
	20	3/4"	50.31	30.42	50.31
	25	1"	90.09	65.52	90.09
	32	1¼"	111.15	-	111.15
	40	1½"	241.02	201.24	241.02
	50	2"	402.48	382.59	402.48
	65	2½"	704.34	603.72	704.34
	80	3"	987.48	955.89	987.48
	100	4"	1710.54	1609.92	1710.54

Cv values in gpm

Pressure rating:	DN	Connection type (code)			
		17	37, 59	60	80, 93
	8	-	-	PN63	-
	10	PN63	-	PN63	-
	15	PN63	PN63	PN63	PN25
	20	PN63	PN63	PN63	PN25
	25	PN63	PN63	PN63	PN25
	32	PN63	-	PN63	-
	40	PN63	PN63	PN63	PN25
	50	PN63	PN63	PN63	PN16
	65	PN40	PN40	PN40	PN16
	80	PN40	PN40	PN40	PN10
	100	PN25	PN25	PN25	PN10

For clamp connections, the permissible pressures are designed for a temperature of 14 to 284 °F when using suitable clamps and sealing materials.

Product conformities

Machinery Directive: 2006/42/EC

Pressure Equipment Directive: 2014/68/EU

Food: FDA
Regulation (EC) No. 1935/2004
Regulation (EC) No. 10/2011

Low Voltage Directive: 2014/35/EU

Explosion protection: ATEX (2014/34/EU), order code Special version X

ATEX marking: The ATEX marking of the product depends on the respective product configuration with valve body and actuator. It can be found in the product-specific ATEX documentation and the ATEX type plate.

EMC Directive: 2014/30/EU

RoHS Directive: 2011/65/EU

Mechanical data**Torques:**

DN	NPS	Seal material (code)	
		5T	5H
8	1/4"	35.40	35.40
10	3/8"	35.40	35.40
15	1/2"	70.81	106.21
20	3/4"	70.81	106.21
25	1"	115.06	168.16
32	1¼"	141.61	194.72
40	1½"	283.22	415.99
50	2"	300.93	451.39
65	2½"	805.42	929.33
80	3"	920.48	1062.09
100	4"	1239.10	1849.81

Free of oil and grease incl. 25% safety
Torques in lbf in

Weight:**Ball valve**

DN	NPS	Connection type (code)			
		17	37, 59	60	80, 93
8	1/4"	-	-	1.10	-
10	3/8"	-	-	1.10	-
15	1/2"	1.76	1.10	1.10	1.10
20	3/4"	1.76	1.10	1.76	1.10
25	1"	2.43	2.20	2.43	2.43
32	1¼"	3.53	-	3.53	-
40	1½"	5.95	4.63	5.95	4.85
50	2"	9.26	7.72	9.26	7.72
65	2½"	18.08	15.43	18.08	15.65
80	3"	25.57	24.25	25.57	26.01
100	4"	52.91	44.09	52.91	45.19

Weight in lb

Technical data of actuator

GEMÜ 9428, 9468 actuators

Mechanical data

Weight:

GEMÜ 9428

Supply voltage 12 V / 24 V:	2.20 lbs
Actuator version 3055:	6.17 lbs

Actuator type 9468

Actuator version 2070:	10.14 lbs
Actuator version 4100, 4200:	25.57 lbs

Product compliance

Machinery Directive: 2006/42/EC

EMC Directive: 2014/30/EU

Low Voltage Directive: 2014/35/EU

RoHS Directive: 2011/65/EU (GEMÜ 9428)

Electrical data

Rated voltage: 12 V / 24 V AC or DC ($\pm 10\%$)

Rated frequency: 50/60 Hz (at AC rated voltage)

Electrical protection class: I (DIN EN 61140)

Power consumption:

Actuator version (code)	Control module (code)	12 V DC (code B1)	12 V AC (code B4)	24 V DC (code C1)	24 V AC (code C4)
1006	A0, AE	30.0	30.0	30.0	30.0
1015	A0, AE	30.0	-	30.0	-
2070	00, 0E, 0P	-	-	63.0	-
4100	00, 0E, 0P	-	-	105.0	-
4200	00, 0E, 0P	-	-	90.0	-

Power consumption in W

Current consumption:

Actuator version (code)	Control module (code)	12 V DC (code B1)	12 V AC (code B4)	24 V DC (code C1)	24 V AC (code C4)
1006	A0, AE	2.2	2.0	1.20	1.5
1015	A0, AE	2.2	-	1.20	-
2070	00, 0E, 0P	-	-	2.60	-
4100	00, 0E, 0P	-	-	4.40	-
4200	00, 0E, 0P	-	-	3.60	-

Current data in A

Technical data of actuator

Max. switching current:

Actuator version (code)	Control module (code)	12 V DC (code B1)	12 V AC (code B4)	24 V DC (code C1)	24 V AC (code C4)
1006	A0, AE	6.3	2.4	4.0	1.8
1015	A0, AE	9.2	-	3.8	-
2070	00, 0E, 0P	-	-	14.0	-
4100	00, 0E, 0P	-	-	35.0	-
4200	00, 0E, 0P	-	-	35.0	-

Current data in A

Input signal: 24 V DC, 24 V AC, 120 V AC, 230 V AC
dependent on rated voltage

Duty cycle: Continuous duty

Electrical protection: **GEMÜ 9428**
Motor protective system by customer

GEMÜ 9468
Internal for functional module 0x
Actuator version 2070: MT 6.3 A
Actuator version 4100, 4200: MT 10.0 A
Motor protective system by customer, see "Recommended motor protection"

Recommended motor protection:

GEMÜ 9428

Voltage	12 V DC	24 V DC
Motor protection switch type	Siemens 3RV 1011-1CA10	Siemens 3RV 1011-1BA10
Set current	2.20	1.70

Current data in A

GEMÜ 9468
Motor protection switch type: Siemens 3RV 1011-1FA10
Set current: 4.0 A

Bernard, J+J actuators

Note: For technical data see manufacturer's original datasheets

Dimensions

Actuator dimensions

GEMÜ 9428, 9468 actuators

Actuator version 1006, 1015, 2015

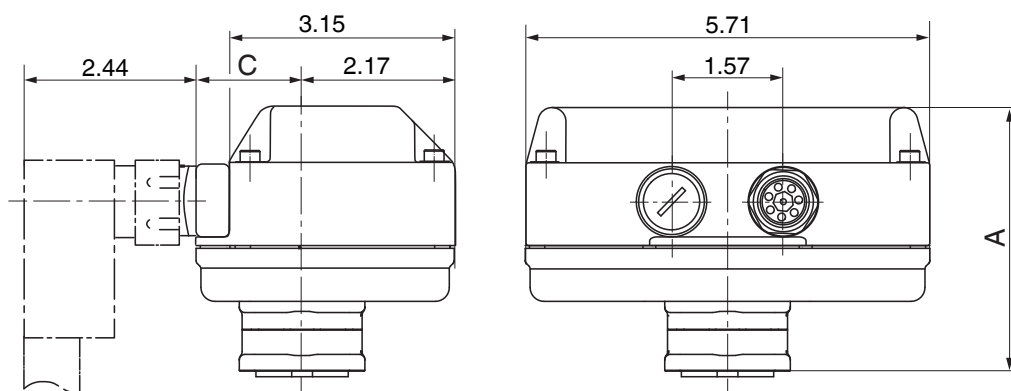

Actuator version	A	C
1006, 1015	3.70	1.93
2015	4.80	2.09

Dimensions in inch

Actuator version 3035, 3055

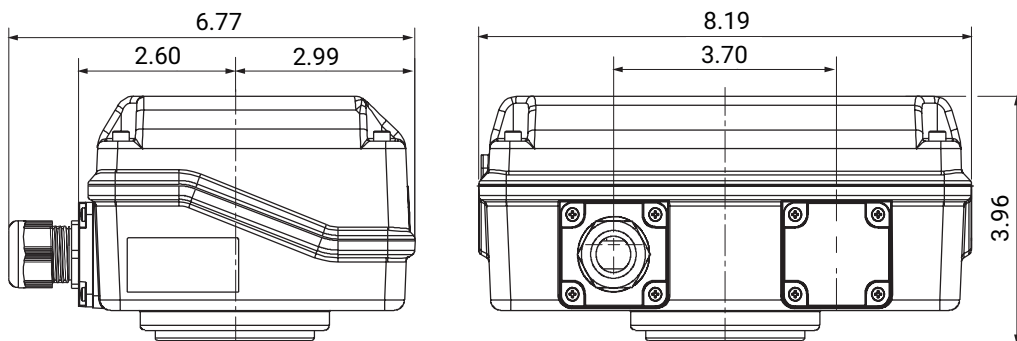

Voltages	B
24 V	3.96
100 V - 250 V	4.90

Dimensions in inch

Dimensions

Actuator version 4100, 4200

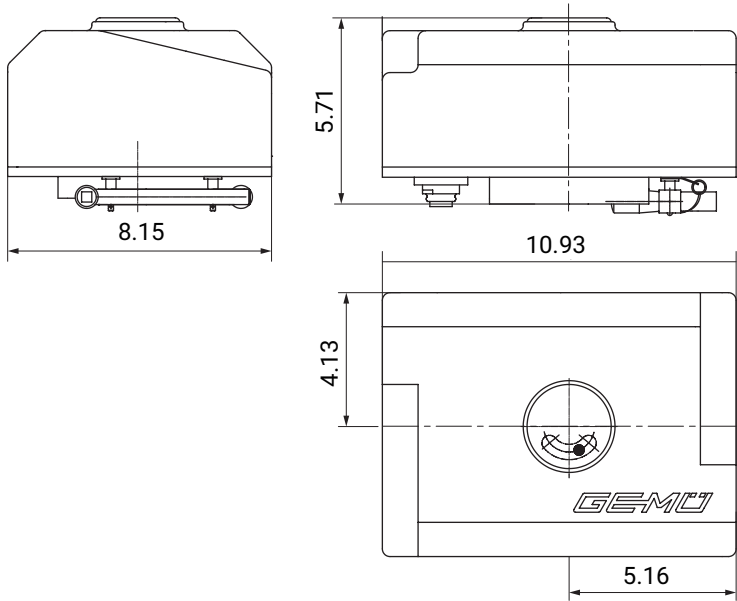

Dimensions in inch

Bernard, AUMA, J+J actuators

For more detailed information on third-party actuators, refer to the manufacturers' documentation

Ball valve

Actuator flange

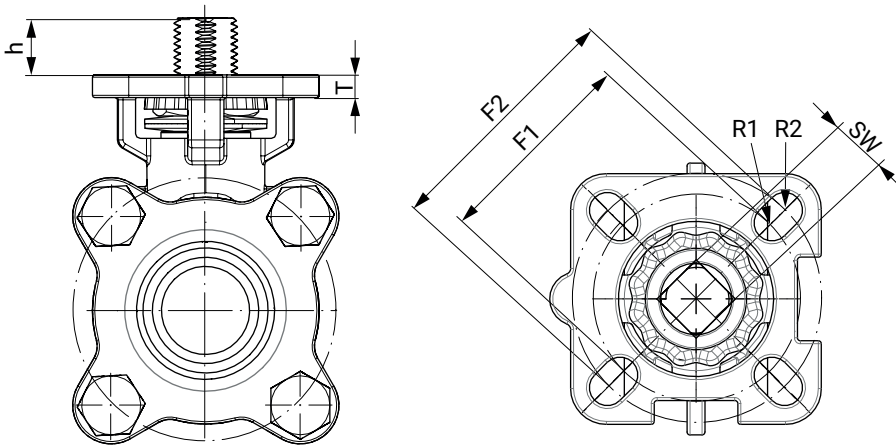

DN	G	F1	ISO 5211 (F1)	R1	F2	ISO 5211 (F2)	R2	SW [mm]	h	T
8	1/4"	1.42	F03	0.12	1.65	F04	0.12	9.0	0.35	0.20
10	3/8"	1.42	F03	0.12	1.65	F04	0.12	9.0	0.35	0.20
15	1/2"	1.42	F03	0.12	1.65	F04	0.12	9.0	0.35	0.20
20	3/4"	1.42	F03	0.12	1.65	F04	0.12	9.0	0.30	0.20
25	1"	1.65	F04	0.12	1.97	F05	0.14	11.0	0.51	0.28
32	1 1/4"	1.65	F04	0.12	1.97	F05	0.14	11.0	0.51	0.28
40	1 1/2"	1.97	F05	0.14	2.76	F07	0.18	14.0	0.59	0.35
50	2"	1.97	F05	0.14	2.76	F07	0.18	14.0	0.63	0.35
65	2 1/2"	1.97	F07	0.14	2.76	F10	0.18	17.0	0.71	0.41
80	3"	2.76	F07	0.18	4.02	F10	0.22	17.0	0.71	0.41

DN	G	F1	ISO 5211 (F1)	R1	F2	ISO 5211 (F2)	R2	SW [mm]	h	T
100	4"	4.02	F10	0.18	4.92	F12	0.22	22.0	1.02	0.41

Dimensions in inch

Body dimensions

Spigot DIN EN 10357 (connection code 17)

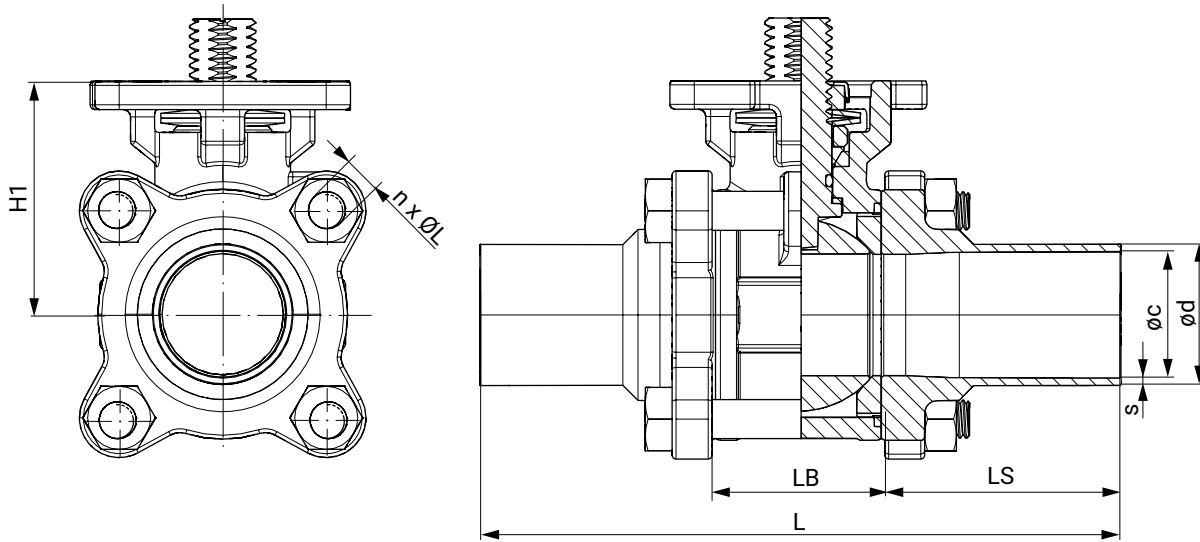

DN	øc	ød	L	LB	LS	H1	n x ØL	s
10	0.39	0.51	4.73	0.96	1.89	1.46	4 x M6	0.06
15	0.63	0.75	5.52	0.96	2.28	1.46	4 x M6	0.06
20	0.79	0.91	5.51	1.23	2.14	1.57	4 x M8	0.06
25	1.02	1.14	5.98	1.34	2.32	1.89	4 x M8	0.06
32	1.26	1.38	6.50	1.73	2.38	2.09	4 x M10	0.06
40	1.50	1.61	7.48	2.17	2.66	2.48	4 x M12	0.06
50	1.97	2.09	7.99	2.71	2.64	2.83	4 x M14	0.06
65	2.60	2.76	10.00	3.23	3.39	3.62	4 x M14	0.08
80	3.19	3.35	11.02	3.78	3.62	4.02	4 x M16	0.08
100	3.94	4.09	12.13	4.80	3.66	5.20	6 x M20	0.08

Dimensions in inch
n = number of bolts

Spigot SMS 3008 (connection code 37)

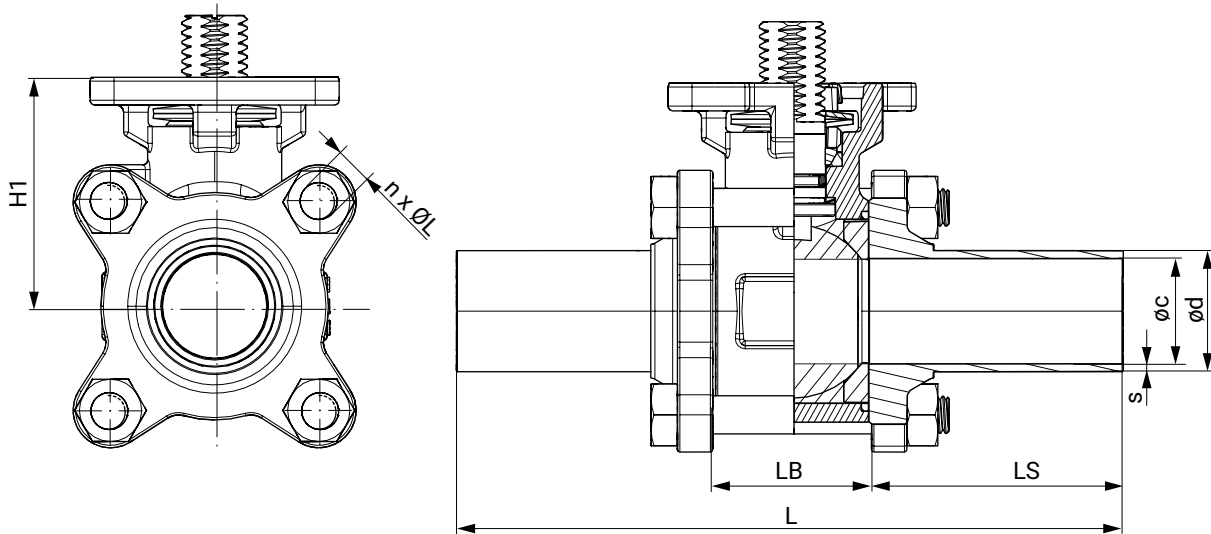

DN	øc	ød	s	t	L	LB	LS	H1	n x ØL
20	0.63	0.71	0.04	0.24	5.60	1.10	2.31	1.50	4 x M6
25	0.89	0.98	0.05	0.29	6.39	1.26	2.56	1.89	4 x M8
40	1.40	1.50	0.05	0.33	7.17	1.81	2.68	2.36	4 x M12
50	1.91	2.01	0.05	0.40	7.60	2.35	2.63	2.72	4 x M14
65	2.37	2.50	0.06	0.49	10.00	3.04	3.48	3.50	4 x M14
80	2.87	3.00	0.06	0.55	10.90	3.61	3.65	3.86	4 x M16
100	3.84	4.00	0.08	0.57	12.00	4.66	3.67	5.12	6 x M16

Dimensions in inch
n = number of bolts

Spigot ASME BPE (connection code 59)

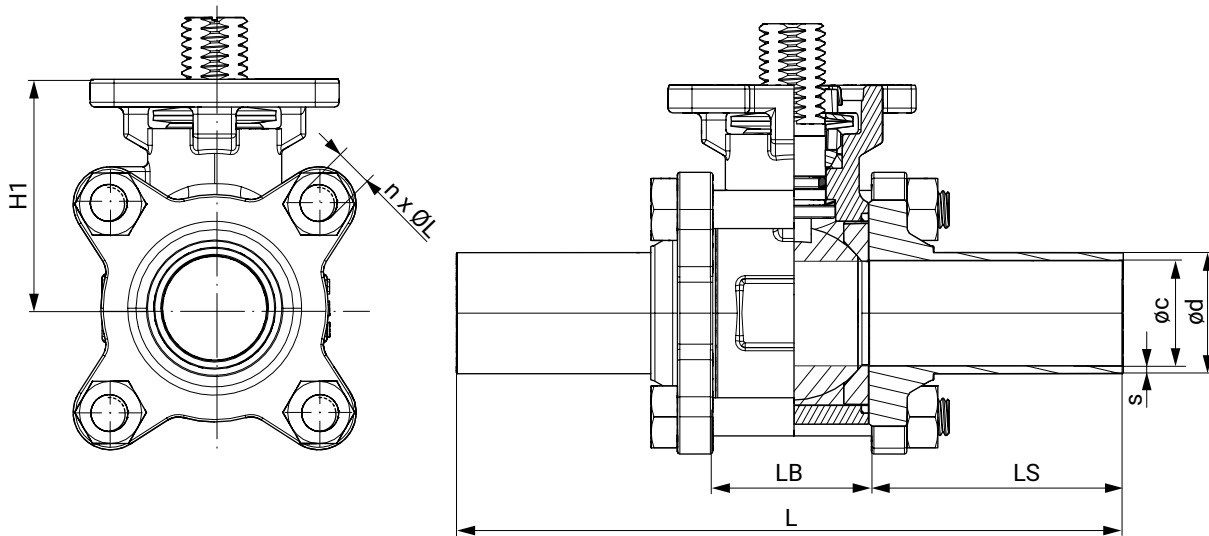

DN	øc	ød	s	L	LB	LS	H1	n x ØL
15	0.37	0.50	0.06	4.90	0.98	1.96	1.50	4 x M6
20	0.62	0.75	0.06	5.60	1.10	2.31	1.50	4 x M6
25	0.87	1.00	0.06	6.39	1.26	2.56	1.89	4 x M8
40	1.37	1.50	0.06	7.17	1.81	2.68	2.36	4 x M12
50	1.87	2.00	0.06	7.60	2.35	2.63	2.72	4 x M14
65	2.37	2.50	0.06	10.00	3.04	3.48	3.50	4 x M14
80	2.87	3.00	0.06	10.90	3.61	3.65	3.86	4 x M16
100	3.83	4.00	0.08	12.00	4.66	3.67	5.12	6 x M16

Dimensions in inch
n = number of bolts

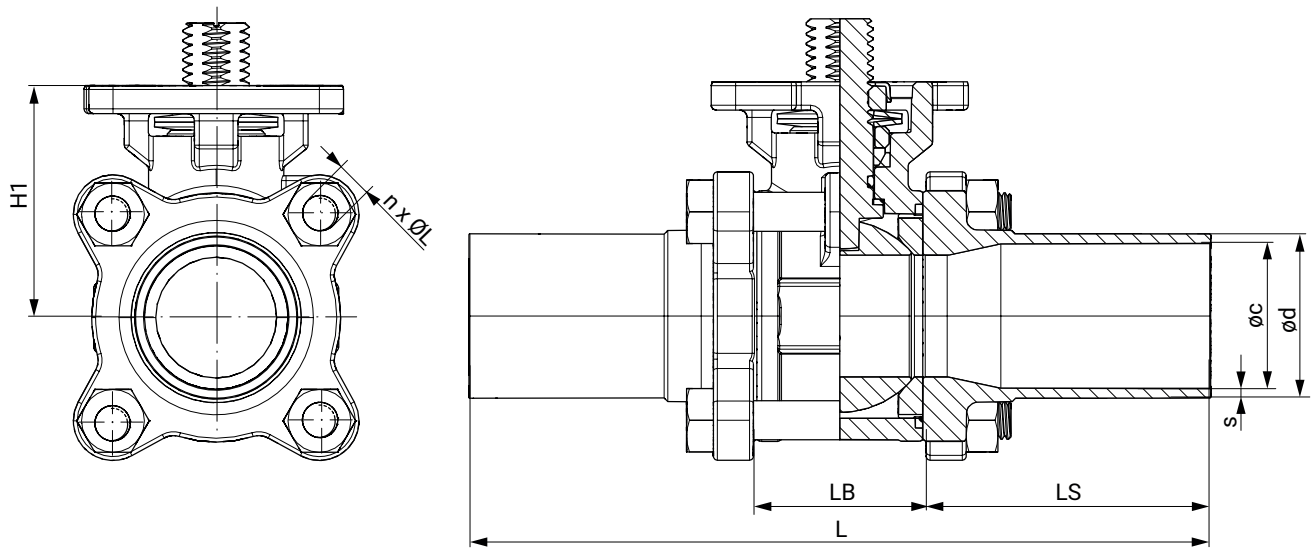
Spigot ISO 1127 / EN 10357 (connection code 60)

DN	Øc	Ød	s	L	LB	LS	H1	n x ØL
8	0.41	0.53	0.06	4.73	0.96	1.89	1.46	4 x M6
10	0.55	0.68	0.06	4.73	0.96	1.89	1.46	4 x M6
15	0.71	0.84	0.06	5.52	0.96	2.28	1.46	4 x M6
20	0.93	1.06	0.06	5.51	1.23	2.14	1.57	4 x M8
25	1.17	1.33	0.08	5.98	1.34	2.32	1.89	4 x M8
32	1.51	1.67	0.08	6.50	1.73	2.38	2.09	4 x M10
40	1.74	1.90	0.08	7.48	2.17	2.66	2.48	4 x M12
50	2.22	2.37	0.08	7.99	2.71	2.64	2.83	4 x M14
65	2.84	3.00	0.08	10.00	3.23	3.39	3.62	4 x M14
80	3.32	3.50	0.09	11.02	3.78	3.62	4.02	4 x M16
100	4.32	4.50	0.09	12.13	4.80	3.66	5.20	6 x M20

Dimensions in inch
n = number of bolts

Dimensions

Clamp ASME BPE (connection code 80)

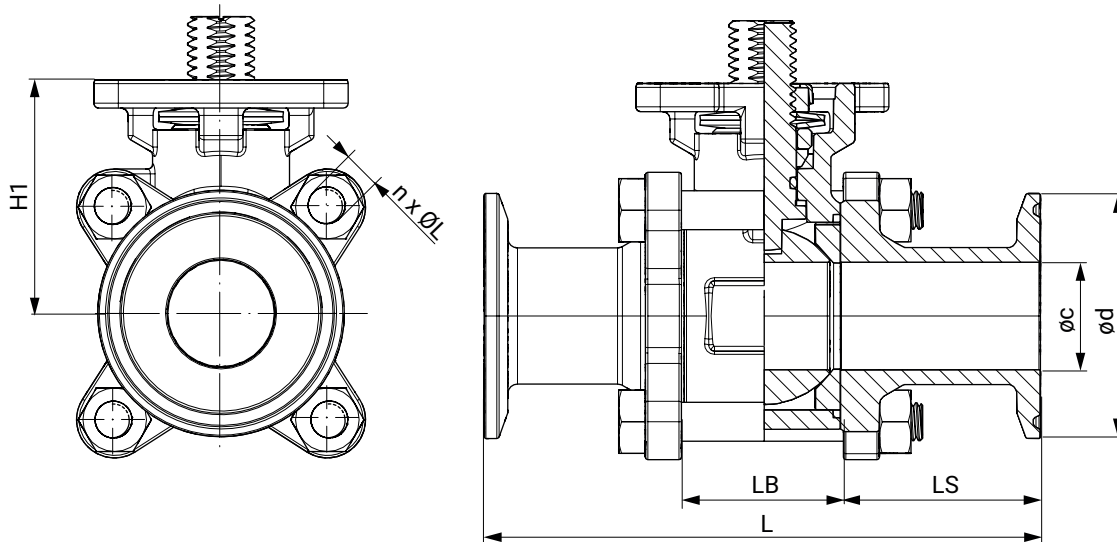

DN	øc	ød	s	L	LB	LS	H1	n x ØL
15	0.37	0.98	0.06	3.50	0.98	1.26	1.50	4 x M6
20	0.62	0.98	0.06	4.00	0.98	1.51	1.50	4 x M6
25	0.87	1.98	0.06	4.50	1.26	1.62	1.89	4 x M8
40	1.37	1.98	0.06	5.50	1.81	1.85	2.36	4 x M12
50	1.87	2.52	0.06	6.25	2.35	1.95	2.72	4 x M14
65	2.37	3.05	0.06	6.75	3.04	1.86	3.50	4 x M14
80	2.87	3.58	0.06	7.73	3.61	2.06	3.86	4 x M16
100	3.83	4.68	0.08	9.50	4.66	2.42	5.12	6 x M16

Dimensions in inch
n = number of bolts

Mixed ends ASME BPE (connection code 93)

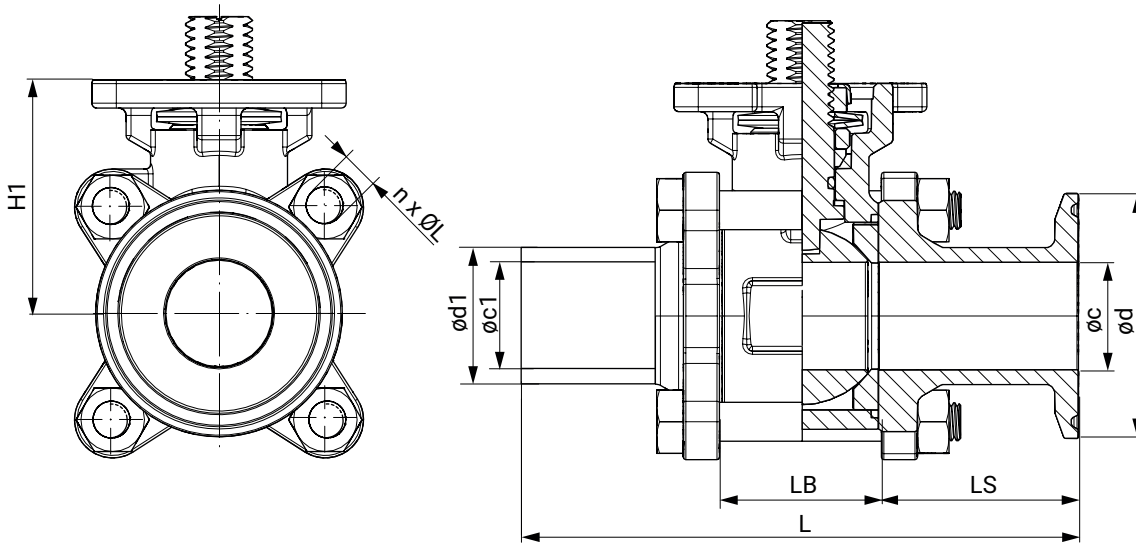

DN	øc	ød	øc1	ød1	s	t	L	LB	LS	H1	n x ØL
15	0.37	0.98	0.37	0.50	0.06	0.24	4.20	0.98	1.96	1.50	4 x M6
20	0.62	0.98	0.62	0.75	0.06	0.24	4.80	1.10	2.31	1.50	4 x M6
25	0.87	1.98	0.87	1.00	0.06	0.29	5.44	1.26	2.56	1.89	4 x M8
40	1.37	1.98	1.37	1.50	0.06	0.33	6.34	1.81	2.68	2.36	4 x M12
50	1.87	2.52	1.87	2.00	0.06	0.40	6.93	2.35	2.63	2.72	4 x M14
65	2.37	3.05	2.37	2.50	0.06	0.49	8.38	3.04	3.48	3.50	4 x M14
80	2.87	3.58	2.87	3.00	0.06	0.55	9.31	3.61	3.65	3.86	4 x M16
100	3.83	4.68	3.83	4.00	0.08	0.57	10.75	4.66	3.67	5.12	6 x M16

Dimensions in inch
n = number of bolts

Electrical connection

Connection and wiring diagram – actuator version 1015, 3035, 3055

ON/OFF actuator (code A0)

12 V DC (code B1) / 24 V DC (code C1)

Assignment of the terminal strips

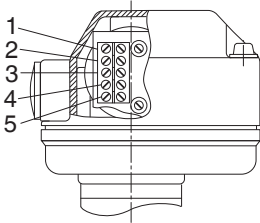

Item	Description
1	Uv+, direction of travel CLOSED
2	Uv-, direction of travel CLOSED
3	Uv+, direction of travel OPEN
4	Uv-, direction of travel OPEN
5	PE, protective earth conductor

Connection diagram

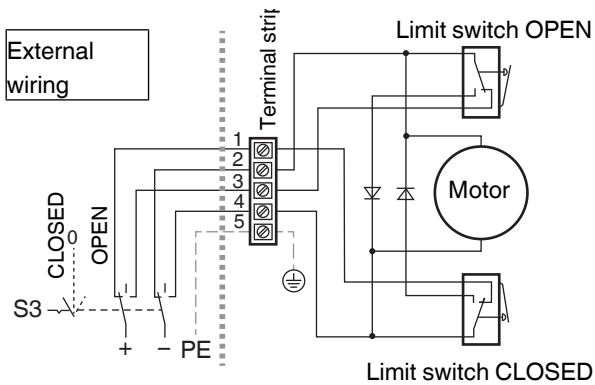

S3	Actuator
CLOSED	Direction of travel CLOSED
0	OFF
OPEN	Direction of travel OPEN

12 V AC (code B4) / 24 V AC (code C4)

Assignment of the terminal strips

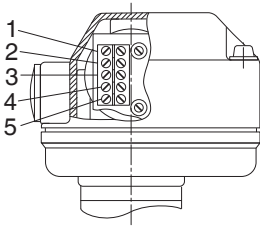

Item	Description
1	L1, supply voltage
2	N, supply voltage
3	L1, change-over (OPEN/CLOSED)
4	N, change-over (OPEN/CLOSED)
5	PE, protective earth conductor

Preferred direction -OPEN- when all signals are present

Connection diagram

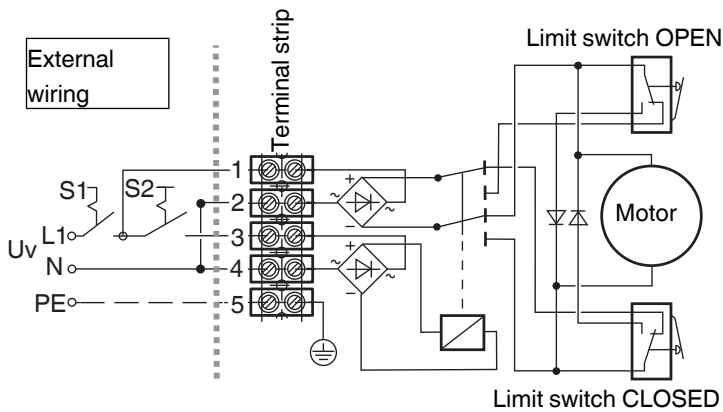

S1	Actuator
0	OFF
1	ON

S2	Direction of travel
0	CLOSED
1	OPEN

ON/OFF actuator with 2 potential-free limit switches (code AE)

12 V DC (code B1) / 24 V DC (code C1)

Position of the connectors

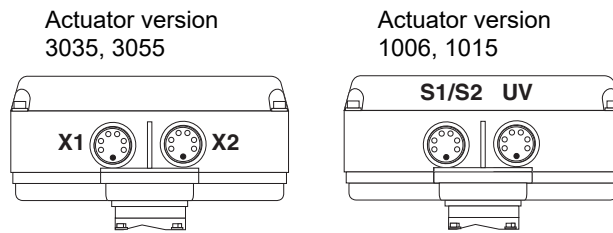

Electrical connection



Plug assignment X1, UV

Pin	Description
1	Uv+, direction of travel CLOSED
2	Uv-, direction of travel CLOSED
3	Uv+, direction of travel OPEN
4	Uv-, direction of travel OPEN
5	n.c.
6	n.c.
⊕	PE, protective earth conductor

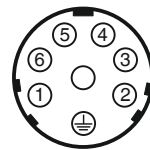

Plug assignment X2, S1/S2

Pin	Description
1	Change-over contact limit switch CLOSED
2	Make contact limit switch CLOSED
3	Break contact limit switch CLOSED
4	Break contact limit switch OPEN
5	Make contact limit switch OPEN
6	Change-over contact limit switch OPEN
⊕	PE, protective earth conductor

Connection diagram

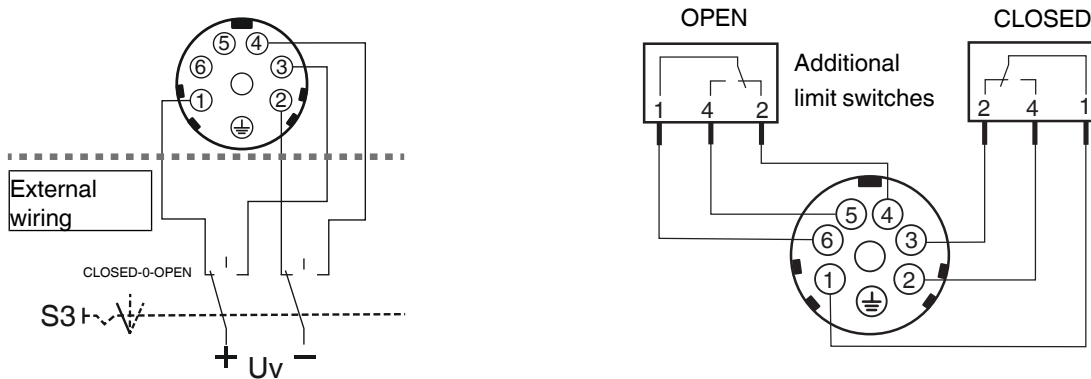

Connection assignment X1, UV

S3	Actuator
CLOSED	Direction of travel CLOSED
0	OFF
OPEN	Direction of travel OPEN

12 V AC (code B4) / 24 V AC (code C4)

Position of the connectors

Actuator version 1006

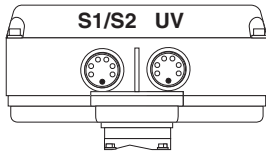

Electrical connection



Plug assignment UV

Pin	Description
1	L1, supply voltage
2	N, supply voltage
3	L1, change-over (OPEN/CLOSED)
4	N, change-over (OPEN/CLOSED)
5	n.c.
6	n.c.
⊕	PE, protective earth conductor



Plug assignment S1/S2

Pin	Description
1	Change-over contact limit switch CLOSED
2	Make contact limit switch CLOSED
3	Break contact limit switch CLOSED
4	Break contact limit switch OPEN
5	Make contact limit switch OPEN
6	Change-over contact limit switch OPEN
⊕	PE, protective earth conductor

Preferred direction -OPEN- when all signals are present

Connection diagram

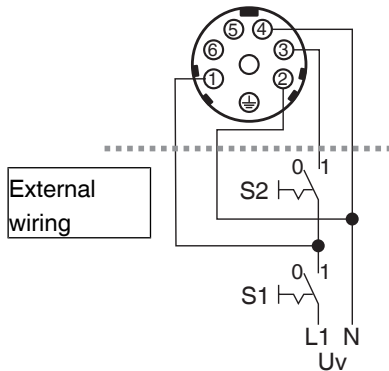

Connection diagram X1, UV

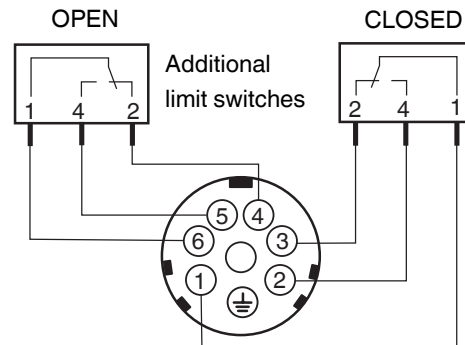

S1	Actuator
0	OFF
1	ON

S2	Direction of travel
0	CLOSED
1	OPEN

Connection/wiring diagram – actuator version 4100, 4200

On/Off actuator with relay (code 00), 24 V DC (code C1)

Position of the connectors

Actuator version 4100, 4200

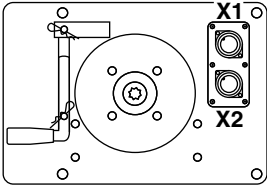

Electrical connection

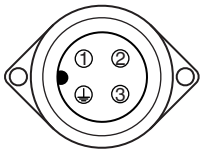

Plug assignment X1

Pin	Description
1	L1 / Uv+, direction of travel CLOSED
2	L1 / Uv+, direction of travel OPEN
3	N / Uv-, neutral conductor
	PE, protective earth conductor

N / L- signals in the unit are separated.

The potential must be assigned by the user.

When the OPEN and CLOSED switches are operated simultaneously the actuator "CLOSES".

Connection diagram

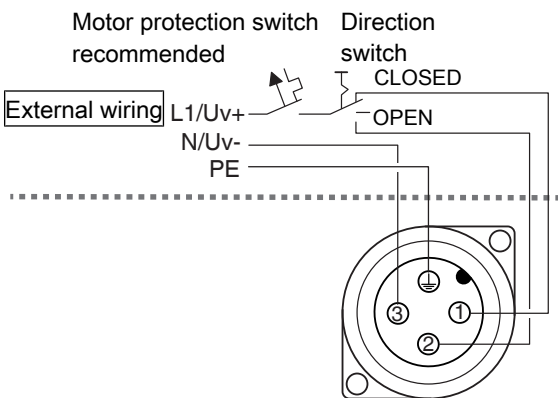

Connection assignment X1

On/Off actuator with 2 additional potential-free limit switches, with relay (code 0E), 24 V DC (code C1)

Position of the connectors

Actuator version 4100, 4200

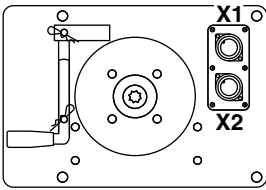

Electrical connection

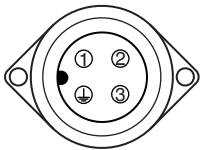

Plug assignment X1

Pin	Description
1	L1 / Uv+, direction of travel CLOSED
2	L1 / Uv+, direction of travel OPEN
3	N / Uv-, neutral conductor
⊕	PE, protective earth conductor

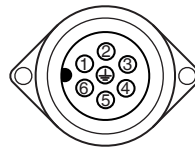

Plug assignment X2

Pin	Description
1	Change-over contact limit switch CLOSED
2	Make contact limit switch CLOSED
3	Break contact limit switch CLOSED
4	Break contact limit switch OPEN
5	Make contact limit switch OPEN
6	Change-over contact limit switch OPEN
⊕	PE, protective earth conductor

N / L- signals in the unit are separated.
 The potential must be assigned by the user.
 When the OPEN and CLOSED switches are operated simultaneously the actuator "CLOSES".

Connection diagram

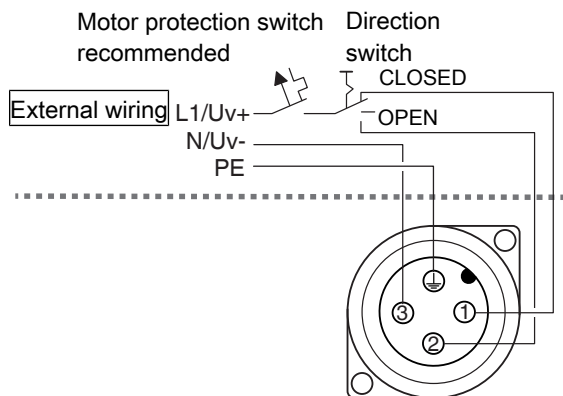

Connection assignment X1

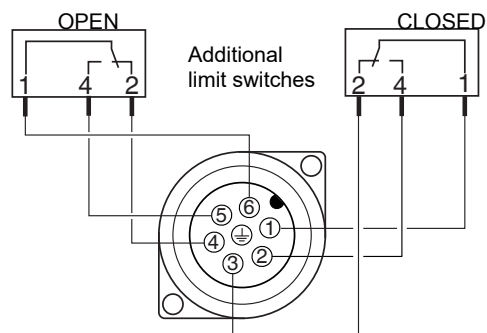

Connection assignment X2

On/Off actuator with potentiometer output, with relay (code 0P), 24 V DC (code C1)

Position of the connectors

Actuator version 4100, 4200

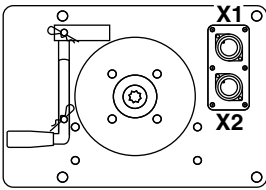

Electrical connection

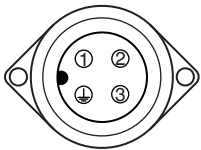

Plug assignment X1

Pin	Description
1	L1 / Uv+, direction of travel CLOSED
2	L1 / Uv+, direction of travel OPEN
3	N / Uv-, neutral conductor
⊕	PE, protective earth conductor

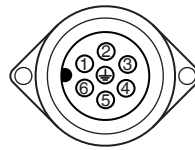

Plug assignment X2

Pin	Description
1	Change-over contact limit switch CLOSED
2	Make contact limit switch CLOSED
3	Break contact limit switch CLOSED
4	Break contact limit switch OPEN
5	Make contact limit switch OPEN
6	Change-over contact limit switch OPEN
⊕	PE, protective earth conductor

N / L- signals in the unit are separated.
 The potential must be assigned by the user.
 When the OPEN and CLOSED switches are operated simultaneously the actuator "CLOSES".

Connection diagram

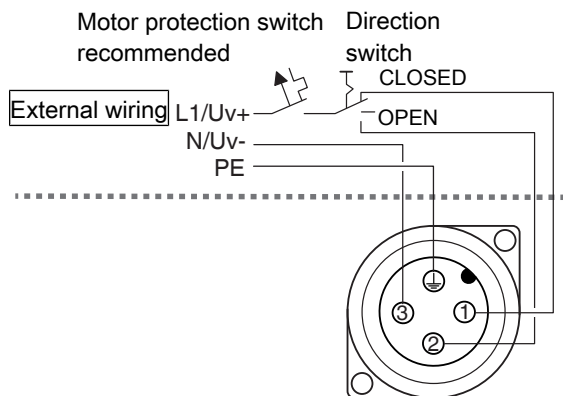

Connection assignment X1

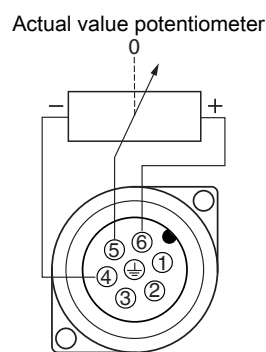

Connection assignment X2

GEMÜ CONEXO

The interaction of valve components that are equipped with RFID chips and an associated IT infrastructure actively increase process reliability.



Thanks to serialization, every valve and every relevant valve component such as the body, actuator or diaphragm, and even automation components, can be clearly traced and read using the CONEXO pen RFID reader. The CONEXO app, which can be installed on mobile devices, not only facilitates and improves the "installation qualification" process, but also makes the maintenance process much more transparent and easier to document. The app actively guides the maintenance technician through the maintenance schedule and directly provides him with all the information assigned to the valve, such as test reports, testing documentation and maintenance histories. The CONEXO portal acts as a central element, helping to collect, manage and process all data.

For further information on GEMÜ CONEXO please visit:

www.gemu-group.com/conexo

Ordering

GEMÜ Conexo must be ordered separately with the ordering option "CONEXO".

Certificates

Certificate	Standard	Item number
2.2 Ferrite content measurement		88081058
2.2 Surface roughness measurement	EN10204 - EN ISO 4288	88079146
3.1 Surface roughness measurement		88094384
3.1 Material	EN 10204	88333336



GEMÜ Gebr. Müller Apparatebau GmbH & Co. KG
Fritz-Müller-Straße 6-8, 74653 Ingelfingen-Criesbach, Germany
Tel. +49 (0)7940 123-0 · info@gemue.de
www.gemu-group.com