

GEMÜ B24

Manually operated ball valve



Features

- Checked delta ferrite material < 3% (1.4435)
- Material certificates for media wetted components
- Media wetted surfaces according to ASME SF5 (Ra 0.51 µm)
- Butt weld spigots in extended orbital welding design
- Optionally available with cavity-filled seat
- Suitable for vacuum applications
- Option: ATEX version
- Ball valve body, assembled free of oil/grease

Description

The GEMÜ B24 3-piece body 2/2-way metal ball valve is manually operated. The 1.4435 stainless steel alloy material composition used for the ball valve body (compliant with 316L) with a low delta ferrite proportion of < 3% is particularly suited to applications in the supply sector for the pharmaceutical, foodstuffs processing and biotechnology (such as water treatment and sterile steam generation) industries. Only those plastics which are compliant with FDA, USP Class VI and Regulation (EU) No.10/2011 are used for the seals.

Technical specifications

- **Media temperature:** 14 to 428 °F
- **Ambient temperature:** -4 to 140 °F
- **Operating pressure:** 0 to 914 psi
- **Body configurations:** 2/2-way body
- **Connection type:** Clamp | Spigot
- **Connection standards:** ASME | DIN | ISO | SMS
- **Body materials:** 1.4435 (316L), investment casting material
- **Seal materials:** PTFE
- **Conformities:** ATEX | EAC | FDA | Reg. (EU) No. 10/2011 | Regulation (EC) No. 1935/2004 | TA Luft (German Clean Air Act) | USP

Technical data depends on the respective configuration



further information
webcode: GW-B24



Product line

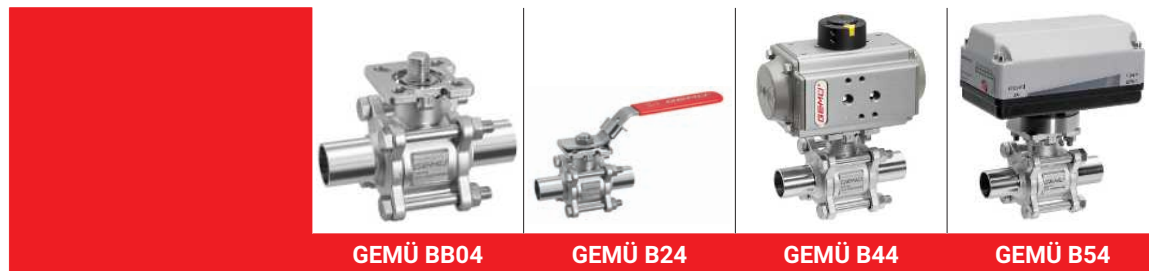

	GEMÜ BB04	GEMÜ B24	GEMÜ B44	GEMÜ B54
Operation				
With bare shaft	●	-	-	-
Manual	-	●	-	-
pneumatic	-	-	●	-
Motorized	-	-	-	●
Nominal sizes	1/4" (DN 8) to 4" (DN 100)	1/4" (DN 8) to 4" (DN 100)	1/4" (DN 8) to 4" (DN 100)	1/4" (DN 8) to 4" (DN 100)
Media temperature	14 to 428 °F	14 to 428 °F	14 to 428 °F	14 to 428 °F
Operating pressure	0 to 914 psi	0 to 914 psi	0 to 914 psi	0 to 914 psi
Connection types				
Clamp	●	●	●	●
Spigot	●	●	●	●

Product description

Construction

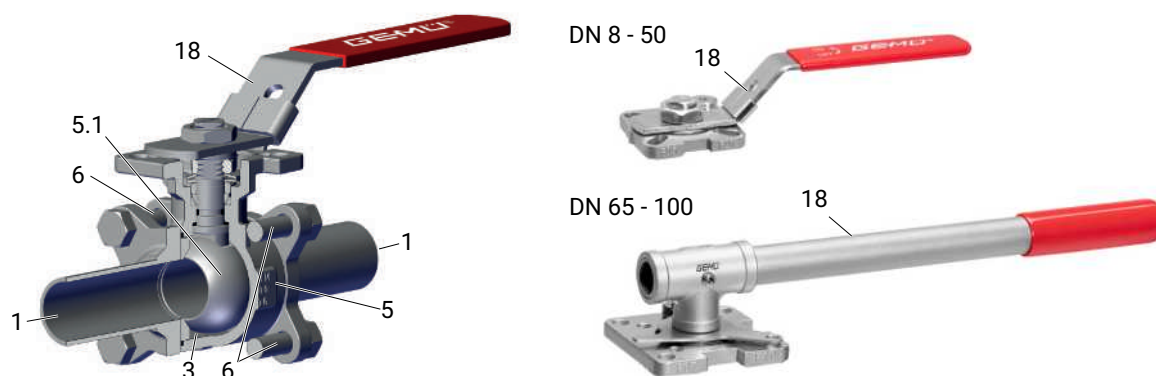

Item	Name	Materials
5	Ball valve body	ASTM A351/1.4435 (316L)
1	Pipe connections	ASTM A351/1.4435 (316L)
5.1	Ball	ASTM A351/1.4435 (316L)
18	Hand lever	304
6	Bolt	A2 70
3	Seal	PTFE

Cavity-filled PTFE seal (Code 5H)



- The cavity-filled seal, which is made of PTFE, is specially designed to reduce excess volumes in the ball cavity.
- Media that remains in the valve's dead spaces is unwanted during food production, for example, and may decontaminate this.
- These deposits accumulate and contaminate the entire process. Thanks to this special seal variant, the volume in the ball cavity is reduced to a minimum.

Application

- Water treatment
- Steam processing
- CIP/SIP
- Waste water treatment
- Storage and distribution
- Drying

The spindle seal system

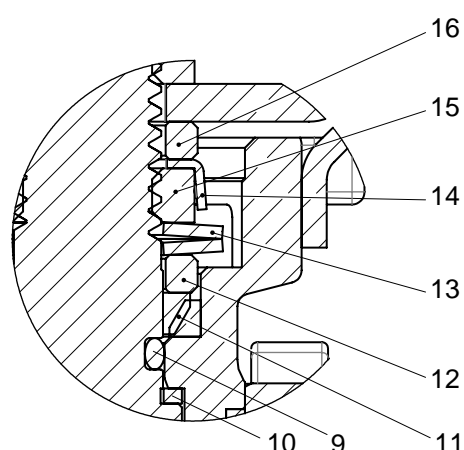

Item	Name	Material
9	O-ring	Viton
10	Seal	PTFE
11	V-ring	PTFE
12	Stainless steel sleeve	SS304-1.4301
13	Spring washer	SS304-1.4301
14	Cap	SS304-1.4301
15	Spindle nut	A2 70
16	Washer	SS304-1.4301

Long service life due to double spindle seal

- Conical spindle seal:

The seal **10** arranged at an angle of 45° effectively prevents the leakage of medium when operating the spindle

- Pretensioned self-adjusting spindle seal:

The spindle packing consists of several V-rings **11**, a spring washer **13** and a stainless steel sleeve **12**. The spring washer **13** is pretensioned via the spindle nut **14**. The pretension force is distributed to the V-rings **11** via the stainless steel sleeve **12**, thereby preventing the leakage of media. The pretension provides low maintenance and reliable spindle sealing even after a long service life.

GEMÜ CONEXO

The interaction of valve components that are equipped with RFID chips and an associated IT infrastructure actively increase process reliability.



Thanks to serialization, every valve and every relevant valve component such as the body, actuator or diaphragm, and even automation components, can be clearly traced and read using the CONEXO pen RFID reader. The CONEXO app, which can be installed on mobile devices, not only facilitates and improves the "installation qualification" process, but also makes the maintenance process much more transparent and easier to document. The app actively guides the maintenance technician through the maintenance schedule and directly provides him with all the information assigned to the valve, such as test reports, testing documentation and maintenance histories. The CONEXO portal acts as a central element, helping to collect, manage and process all data.

For further information on GEMÜ CONEXO please visit:

www.gemu-group.com/conexo

Ordering

GEMÜ Conexo must be ordered separately with the ordering option "CONEXO".

Installing the RFID chip

In the corresponding design with CONEXO, this product has an RFID chip for electronic identification purposes. The position of the RFID chip can be seen below.

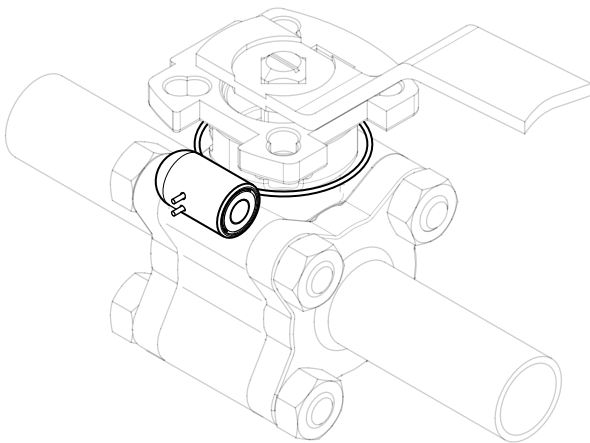

Availability

DN	NPS	Connection type code ¹⁾					
		17	37	59	60	80	93
8	1/4"	-	-	-	X	-	-
10	3/8"	X	-	-	X	-	-
15	1/2"	X	-	X	X	X	X
20	3/4"	X	X	X	X	X	X
25	1"	X	X	X	X	X	X
32	1¼"	X	-	-	X	-	-
40	1½"	X	X	X	X	X	X
50	2"	X	X	X	X	X	X
65	2½"	X	X	X	X	X	X
80	3"	X	X	X	X	X	X
100	4"	X	X	X	X	X	X

1) Connection type

Code 17: Spigot EN 10357 series A/DIN 11866 series A formerly DIN 11850 series 2

Code 37: Spigot SMS 3008

Code 59: Spigot ASME BPE/DIN EN 10357 series C (from 2022 edition)/DIN 11866 series C

Code 60: Spigot ISO 1127/DIN EN 10357 series C (2014 edition)/DIN 11866 series B

Code 80: Clamp ASME BPE

Code 93: On one side, clamp ASME BPE corresponding to code 80, on the other side, butt weld spigot code 59, for pipe ASME BPE

Order data

The order data provide an overview of standard configurations.

Please check the availability before ordering. Other configurations available on request.

Products ordered with **bold marked ordering options** are so-called preferred series. Depending on the nominal size, these are available more quickly.

Order codes

1 Type	Code
Ball valve, metal, manually operated, three-piece body, sanitary, checked delta ferrite material and media wetted surfaces according to ASME SF5, ISO 5211, top flange, lockable hand lever, low maintenance spindle seal and blow-out proof shaft, with antistatic unit	B24

2 DN	Code
DN 8	8
DN 10	10
DN 15	15
DN 20	20
DN 25	25
DN 32	32
DN 40	40
DN 50	50
DN 65	65
DN 80	80
DN 100	100

3 Body/ball configuration	Code
2/2-way body	D

4 Connection type	Code
Spigot EN 10357 series A/DIN 11866 series A formerly DIN 11850 series 2	17
Spigot SMS 3008	37
Spigot ASME BPE/DIN EN 10357 series C (from 2022 edition)/DIN 11866 series C	59
Spigot ISO 1127/DIN EN 10357 series C (2014 edition)/DIN 11866 series B	60
Clamp ASME BPE	80
On one side, clamp ASME BPE corresponding to code 80, on the other side, butt weld spigot code 59, for pipe ASME BPE	93

5 Ball valve material	Code
1.4435/ASTM A351, low ferrite <3% (equivalent to 316L $\Delta Fe < 3\%$) (body, connection, ball), 1.4409/SS316L (spindle)	C3

6 Seal material	Code
PTFE (FDA certification)	5T
PTFE (FDA certification), cavity filled	5H

7 Control function	Code
Manually operated, hand lever, lockable	L

8 Type of design	Code
Standard	
Ra $\leq 0.4 \mu\text{m}$ (15 $\mu\text{in.}$) for media wetted surfaces *), in accordance with DIN 11866 HE4, electropolished internal/external, *) for inner pipe diameter $\leq 6 \text{ mm}$, in spigot Ra $\leq 0.8 \mu\text{m}$	1537
K-NO SF5, K-NO 7056, SF5 – Ra max. $0.51 \mu\text{m}$ (20 $\mu\text{in.}$) electropolished internal/external, 7056 – drilled shaft, shortened hand lever	7137
K-NO SF5, K-NO 0101, SF5 – Ra max. $0.51 \mu\text{m}$ (20 $\mu\text{in.}$) electropolished internal/external, 0101 – media wetted area cleaned to ensure suitability for paint applications	7140
K-NO SF5, K-NO 0104, SF5 – Ra max. $0.51 \mu\text{m}$ (20 $\mu\text{in.}$) electropolished internal/external, 0104 – media wetted parts cleaned for high purity media and packed in plastic bag	7141
K-NO SF5, K-NO 0107, SF5 – Ra max. $0.51 \mu\text{m}$ (20 $\mu\text{in.}$) electropolished internal/external, 0107 – valve free of oil and grease, media wetted area cleaned	7142
Ra max. $0.38 \mu\text{m}$ (15 $\mu\text{in.}$) for media wetted surfaces, in accordance with ASME BPE SF4, electropolished internal/external	SF4
Ra max. $0.51 \mu\text{m}$ (20 $\mu\text{in.}$) for media wetted surfaces, in accordance with ASME BPE SF5, electropolished internal/external	SF5

9 Special version	Code
Without	
ATEX version	X

10 CONEXO	Code
Without	
Integrated RFID chip for electronic identification and traceability	C

Order example

Order option	Code	Description
1 Type	B24	Ball valve, metal, manually operated, three-piece body, sanitary, checked delta ferrite material and media wetted surfaces according to ASME SF5, ISO 5211, top flange, lockable hand lever, low maintenance spindle seal and blow-out proof shaft, with antistatic unit
2 DN	15	DN 15
3 Body/ball configuration	D	2/2-way body
4 Connection type	59	Spigot ASME BPE/DIN EN 10357 series C (from 2022 edition)/DIN 11866 series C
5 Ball valve material	C3	1.4435/ASTM A351, low ferrite <3% (equivalent to 316L Δ Fe<3%) (body, connection, ball), 1.4409/SS316L (spindle)
6 Seal material	5T	PTFE (FDA certification)
7 Control function	L	Manually operated, hand lever, lockable
8 Type of design		Standard
9 Special version		Without
10 CONEXO		Without

Technical data

Medium

Working medium: Corrosive, inert, gaseous and liquid media and steam which have no negative impact on the physical and chemical properties of the body and seal material.

Temperature

Media temperature: 14 – 428 °F

Ambient temperature: -4 – 140 °F

Storage temperature: -76 – 140 °F

Pressure

Operating pressure: 0 – 914 psi

Vacuum: Can be used up to a vacuum of 1.5 inhg (absolute)
 These values apply to room temperature and air. The values may deviate for other media and other temperatures.

Pressure/temperature diagram:

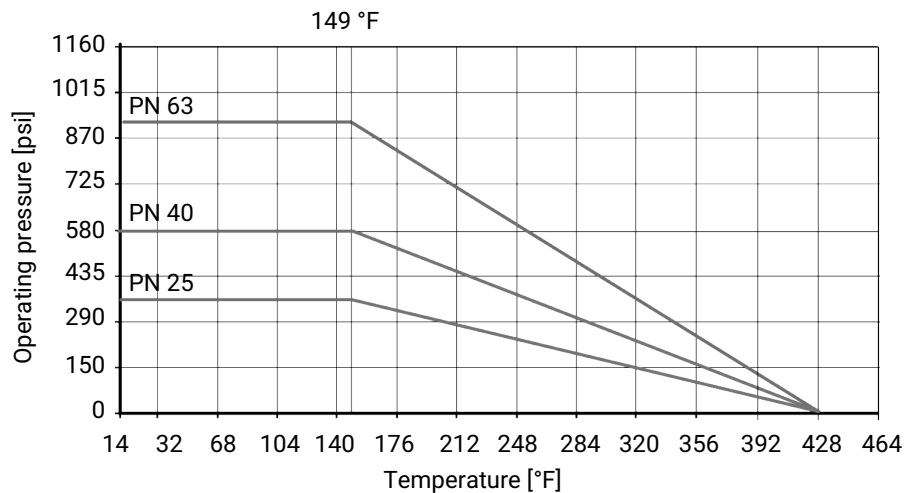

Pressure/temperature data in accordance with diagram refers to static operating conditions. Strongly fluctuating or fast-changing parameters can lead to a reduction of the service life. Special applications must be talked through with your technical contact person in advance.

Use the clamped union with the correct pressure rating for a safe and correct pipeline design. Pressure ratings of the clamp alone are generally higher, but do not take into account the fully clamped assembly with gasket

Leakage rate: Leakage rate according to ANSI FCI70 – B16.104
 Leakage rate according to EN 12266, 87 psi air, leakage rate A

Cv-values:

DN	NPS	Connection type (code)		
		17	37, 59, 80, 93	60
8	1/4"	8.19	-	8.19
10	3/8"	8.19	-	8.19
15	1/2"	21.06	10.53	21.06
20	3/4"	50.31	30.42	50.31
25	1"	90.09	65.52	90.09
32	1¼"	111.15	-	111.15
40	1½"	241.02	201.24	241.02
50	2"	402.48	382.59	402.48
65	2½"	704.34	603.72	704.34
80	3"	987.48	955.89	987.48
100	4"	1710.54	1609.92	1710.54

Cv values in gpm

Pressure rating:

DN	Connection type (code)			
	17	37, 59	60	80, 93
8	-	-	PN63	-
10	PN63	-	PN63	-
15	PN63	PN63	PN63	PN25
20	PN63	PN63	PN63	PN25
25	PN63	PN63	PN63	PN25
32	PN63	-	PN63	-
40	PN63	PN63	PN63	PN25
50	PN63	PN63	PN63	PN16
65	PN40	PN40	PN40	PN16
80	PN40	PN40	PN40	PN10
100	PN25	PN25	PN25	PN10

For clamp connections, the permissible pressures are designed for a temperature of 14 to 284 °F when using suitable clamps and sealing materials.

Product conformities

Pressure Equipment Directive: 2014/68/EU

Food: FDA
Regulation (EC) No. 1935/2004
Regulation (EC) No. 10/2011

Explosion protection: ATEX (2014/34/EU), order code Special version X

ATEX assessment:

External
Gas: Zone 1, 2 IIC
Dust: Zone 21, 22 IIIC

Internal
Up to DN 32
Gas: Zone 1, 2 IIC
Dust: Zone 21, 22 IIIC

DN 40 to 100
Gas: Zone 1, 2 IIB
Dust: Zone 21, 22 IIIB

Mechanical data

Torques:

DN	NPS	Seal material (code)	
		5T	5H
8	1/4"	35.40	35.40
10	3/8"	35.40	35.40
15	1/2"	70.81	106.21
20	3/4"	70.81	106.21
25	1"	115.06	168.16
32	1¼"	141.61	194.72
40	1½"	283.22	415.99
50	2"	300.93	451.39
65	2½"	805.42	929.33
80	3"	920.48	1062.09
100	4"	1239.10	1849.81

Free of oil and grease incl. 25% safety
Torques in lbf in

Weight:

Ball valve

DN	NPS	Connection type (code)			
		17	37, 59	60	80, 93
8	1/4"	-	-	1.10	-
10	3/8"	-	-	1.10	-
15	1/2"	1.76	1.10	1.10	1.10
20	3/4"	1.76	1.10	1.76	1.10
25	1"	2.43	2.20	2.43	2.43
32	1¼"	3.53	-	3.53	-
40	1½"	5.95	4.63	5.95	4.85
50	2"	9.26	7.72	9.26	7.72
65	2½"	18.08	15.43	18.08	15.65
80	3"	25.57	24.25	25.57	26.01
100	4"	52.91	44.09	52.91	45.19

Weight in lb

Hand lever

DN	Designation	Weight
8 - 20	AB24 20D	0.27
25 - 32	AB24 32D	0.36
40 - 50	AB24 50D	0.88
65 - 80	AB24 80D	1.72
100	AB24100D	2.12

Weight in lb

Dimensions

Actuator flange

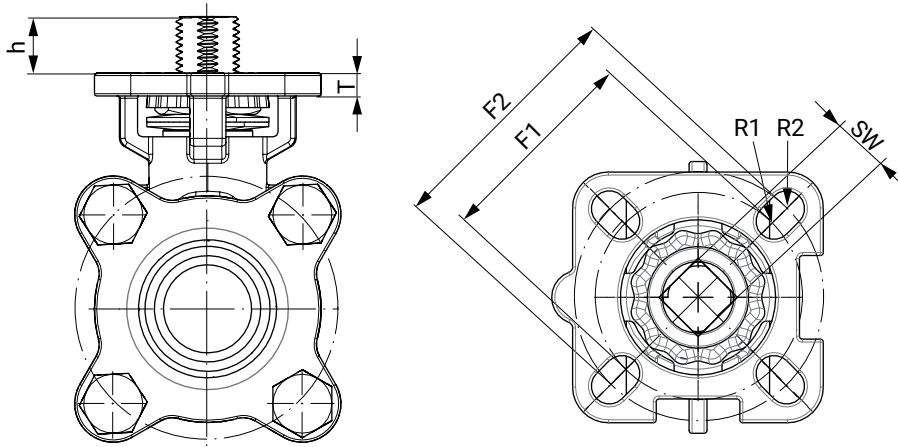

DN	G	F1	ISO 5211 (F1)	R1	F2	ISO 5211 (F2)	R2	SW [mm]	h	T
8	1/4"	1.42	F03	0.12	1.65	F04	0.12	9.0	0.35	0.20
10	3/8"	1.42	F03	0.12	1.65	F04	0.12	9.0	0.35	0.20
15	1/2"	1.42	F03	0.12	1.65	F04	0.12	9.0	0.35	0.20
20	3/4"	1.42	F03	0.12	1.65	F04	0.12	9.0	0.30	0.20
25	1"	1.65	F04	0.12	1.97	F05	0.14	11.0	0.51	0.28
32	1 1/4"	1.65	F04	0.12	1.97	F05	0.14	11.0	0.51	0.28
40	1 1/2"	1.97	F05	0.14	2.76	F07	0.18	14.0	0.59	0.35
50	2"	1.97	F05	0.14	2.76	F07	0.18	14.0	0.63	0.35
65	2 1/2"	1.97	F07	0.14	2.76	F10	0.18	17.0	0.71	0.41
80	3"	2.76	F07	0.18	4.02	F10	0.22	17.0	0.71	0.41
100	4"	4.02	F10	0.18	4.92	F12	0.22	22.0	1.02	0.41

Dimensions in inch

Spigot DIN EN 10357 (connection code 17)

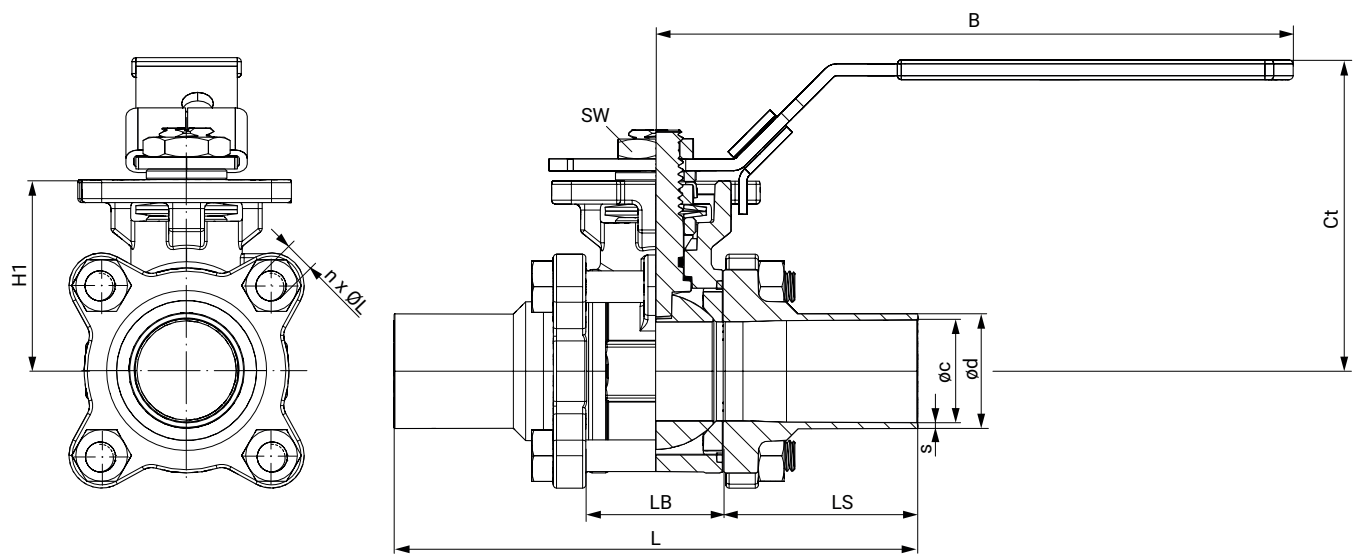

DN	øc	ød	L	LB	LS	H1	n x ØL	s	SW [mm]	Ct	B
10	0.39	0.51	4.73	0.96	1.89	1.46	4 x M6	0.06	19.0	2.62	4.92
15	0.63	0.75	5.52	0.96	2.28	1.46	4 x M6	0.06	19.0	2.62	4.92
20	0.79	0.91	5.51	1.23	2.14	1.57	4 x M8	0.06	19.0	2.74	4.92
25	1.02	1.14	5.98	1.34	2.32	1.89	4 x M8	0.06	22.0	3.09	6.30
32	1.26	1.38	6.50	1.73	2.38	2.09	4 x M10	0.06	22.0	3.29	6.30
40	1.50	1.61	7.48	2.17	2.66	2.48	4 x M12	0.06	27.0	4.09	7.95
50	1.97	2.09	7.99	2.71	2.64	2.83	4 x M14	0.06	27.0	4.45	7.95
65	2.60	2.76	10.00	3.23	3.39	3.62	4 x M14	0.08	32.0	5.51	11.81
80	3.19	3.35	11.02	3.78	3.62	4.02	4 x M16	0.08	32.0	5.91	11.81
100	3.94	4.09	12.13	4.80	3.66	5.20	6 x M20	0.08	38.0	7.37	13.78

Dimensions in inch
n = number of bolts

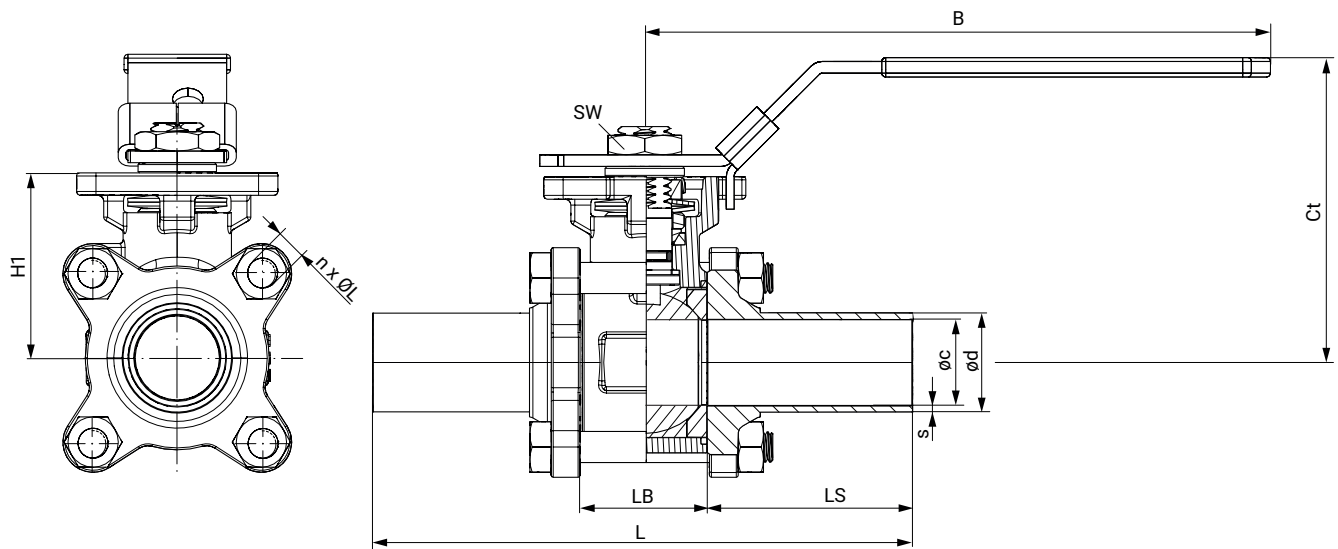
Spigot SMS 3008 (connection code 37)

DN	øc	ød	s	t	L	LB	LS	H1	n x ØL	Ct	B	SW [mm]
20	0.63	0.71	0.04	0.24	5.60	1.10	2.31	1.50	4 x M6	2.66	4.92	19.0
25	0.89	0.98	0.05	0.29	6.39	1.26	2.56	1.89	4 x M8	3.09	6.30	22.0
40	1.40	1.50	0.05	0.33	7.17	1.81	2.68	2.36	4 x M12	3.97	7.95	27.0
50	1.91	2.01	0.05	0.40	7.60	2.35	2.63	2.72	4 x M14	4.32	7.95	27.0
65	2.37	2.50	0.06	0.49	10.00	3.04	3.48	3.50	4 x M14	5.40	11.81	32.0
80	2.87	3.00	0.06	0.55	10.90	3.61	3.65	3.86	4 x M16	5.76	11.81	32.0
100	3.84	4.00	0.08	0.57	12.00	4.66	3.67	5.12	6 x M16	7.31	13.78	38.0

Dimensions in inch
n = number of bolts

Spigot ASME BPE (connection code 59)

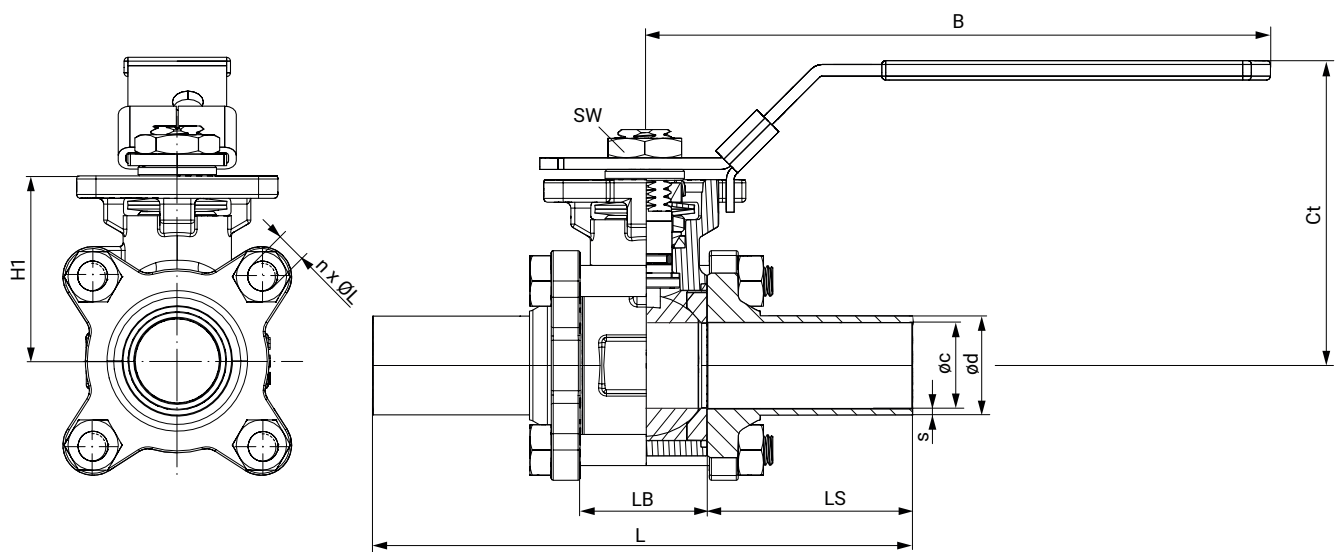

DN	øc	ød	s	L	LB	LS	H1	n x ØL	Ct	B	SW [mm]
15	0.37	0.50	0.06	4.90	0.98	1.96	1.50	4 x M6	2.66	4.92	19.0
20	0.62	0.75	0.06	5.60	1.10	2.31	1.50	4 x M6	2.66	4.92	19.0
25	0.87	1.00	0.06	6.39	1.26	2.56	1.89	4 x M8	3.09	6.30	22.0
40	1.37	1.50	0.06	7.17	1.81	2.68	2.36	4 x M12	3.97	7.95	27.0
50	1.87	2.00	0.06	7.60	2.35	2.63	2.72	4 x M14	4.32	7.95	27.0
65	2.37	2.50	0.06	10.00	3.04	3.48	3.50	4 x M14	5.40	11.81	32.0
80	2.87	3.00	0.06	10.90	3.61	3.65	3.86	4 x M16	5.76	11.81	32.0
100	3.83	4.00	0.08	12.00	4.66	3.67	5.12	6 x M16	7.31	13.78	38.0

Dimensions in inch
n = number of bolts

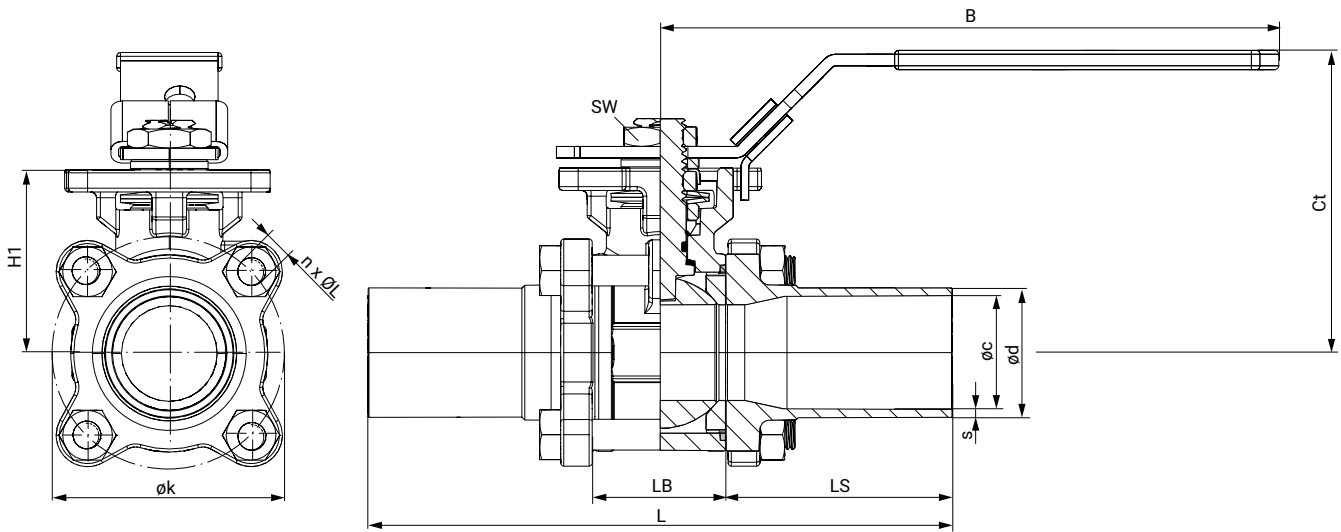
Spigot ISO 1127 / EN 10357 (connection code 60)

DN	ϕc	ϕd	s	L	LB	LS	H1	n x ϕL	Ct	B	SW [mm]
8	0.41	0.53	0.06	4.73	0.96	1.89	1.46	4 x M6	2.62	4.92	19.0
10	0.55	0.68	0.06	4.73	0.96	1.89	1.46	4 x M6	2.62	4.92	19.0
15	0.71	0.84	0.06	5.52	0.96	2.28	1.46	4 x M6	2.62	4.92	19.0
20	0.93	1.06	0.06	5.51	1.23	2.14	1.57	4 x M8	2.74	4.92	19.0
25	1.17	1.33	0.08	5.98	1.34	2.32	1.89	4 x M8	3.09	6.30	22.0
32	1.51	1.67	0.08	6.50	1.73	2.38	2.09	4 x M10	3.29	6.30	22.0
40	1.74	1.90	0.08	7.48	2.17	2.66	2.48	4 x M12	4.09	7.95	27.0
50	2.22	2.37	0.08	7.99	2.71	2.64	2.83	4 x M14	4.45	7.95	27.0
65	2.84	3.00	0.08	10.00	3.23	3.39	3.62	4 x M14	5.51	11.81	32.0
80	3.32	3.50	0.09	11.02	3.78	3.62	4.02	4 x M16	5.91	11.81	32.0
100	4.32	4.50	0.09	12.13	4.80	3.66	5.20	6 x M20	7.37	13.78	38.0

Dimensions in inch
n = number of bolts

Clamp ASME BPE (connection code 80)

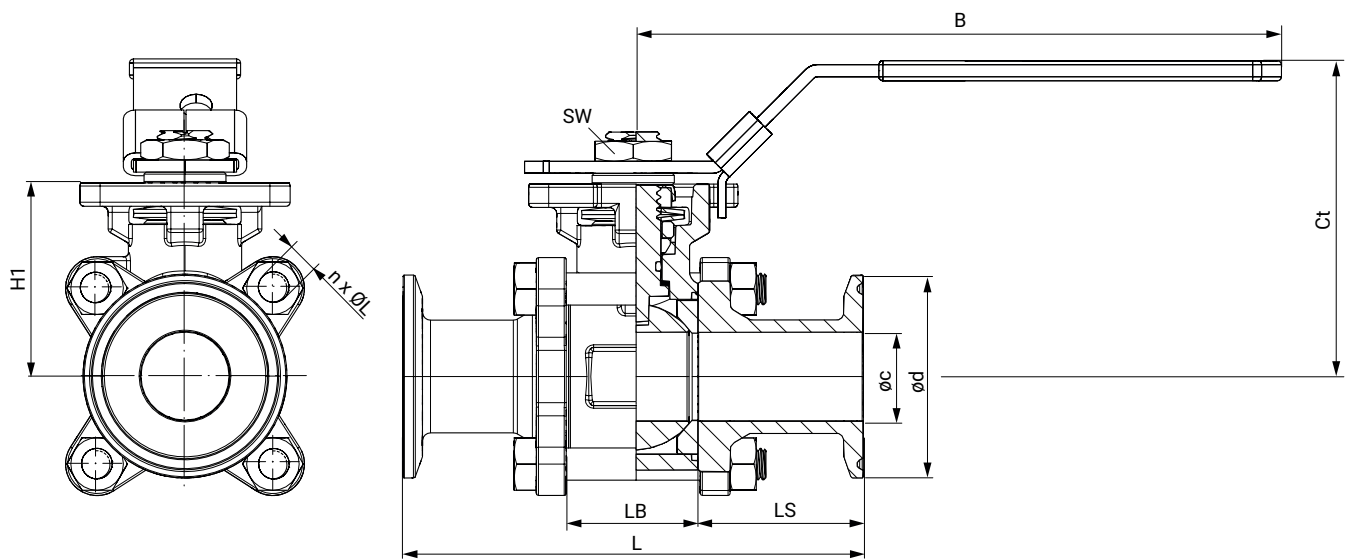

DN	Øc	Ød	s	L	LB	LS	H1	n x ØL	Ct	B	SW [mm]
15	0.37	0.98	0.06	3.50	0.98	1.26	1.50	4 x M6	2.66	4.92	19.0
20	0.62	0.98	0.06	4.00	0.98	1.51	1.50	4 x M6	2.66	4.92	19.0
25	0.87	1.98	0.06	4.50	1.26	1.62	1.89	4 x M8	3.09	6.30	22.0
40	1.37	1.98	0.06	5.50	1.81	1.85	2.36	4 x M12	3.97	7.95	27.0
50	1.87	2.52	0.06	6.25	2.35	1.95	2.72	4 x M14	4.32	7.95	27.0
65	2.37	3.05	0.06	6.75	3.04	1.86	3.50	4 x M14	5.40	11.81	32.0
80	2.87	3.58	0.06	7.73	3.61	2.06	3.86	4 x M16	5.76	11.81	32.0
100	3.83	4.68	0.08	9.50	4.66	2.42	5.12	6 x M16	7.31	13.78	38.0

Dimensions in inch
n = number of bolts

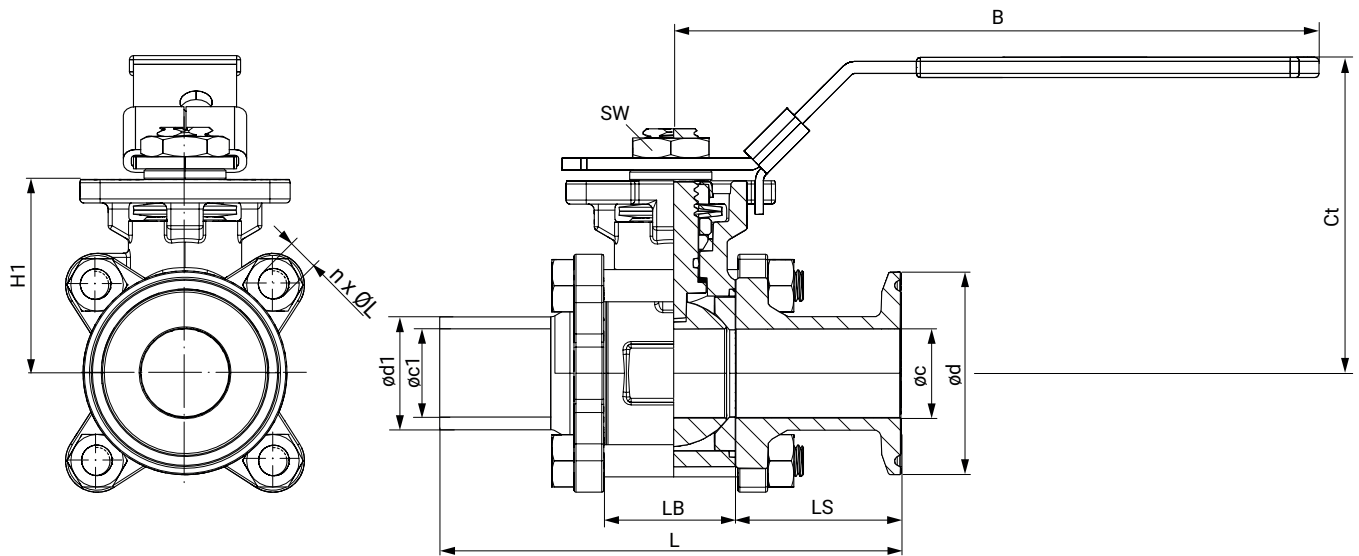
Mixed ends ASME BPE (connection code 93)

DN	øc	ød	øc1	ød1	s	t	L	LB	LS	H1	n x ØL	Ct	B	SW [mm]
15	0.37	0.98	0.37	0.50	0.06	0.24	4.20	0.98	1.96	1.50	4 x M6	2.66	4.92	19.0
20	0.62	0.98	0.62	0.75	0.06	0.24	4.80	1.10	2.31	1.50	4 x M6	2.66	4.92	19.0
25	0.87	1.98	0.87	1.00	0.06	0.29	5.44	1.26	2.56	1.89	4 x M8	3.09	6.30	22.0
40	1.37	1.98	1.37	1.50	0.06	0.33	6.34	1.81	2.68	2.36	4 x M12	3.97	7.95	27.0
50	1.87	2.52	1.87	2.00	0.06	0.40	6.93	2.35	2.63	2.72	4 x M14	4.32	7.95	27.0
65	2.37	3.05	2.37	2.50	0.06	0.49	8.38	3.04	3.48	3.50	4 x M14	5.40	11.81	32.0
80	2.87	3.58	2.87	3.00	0.06	0.55	9.31	3.61	3.65	3.86	4 x M16	5.76	11.81	32.0
100	3.83	4.68	3.83	4.00	0.08	0.57	10.75	4.66	3.67	5.12	6 x M16	7.31	13.78	38.0

Dimensions in inch
n = number of bolts

Accessories



GEMÜ LSF

Inductive dual sensor for quarter turn valves

The GEMÜ LSF inductive dual sensor is suitable for mounting to manually and pneumatically operated quarter turn valves. It is also fitted with an optical position indicator for visual confirmation of position.

Only permissible with K-no. 7137.

Nominal size	Item no.	Designation
DN 8-20	88470175	LSFS01Z BV F04 M5
DN 25-32	88470177	LSFS01Z BV F05 M6
DN 40-50	88470178	LSFS01Z BV F07 M6
DN 65-80	88836073	LSFS01Z BV F10 M6
DN 100	88836075	LSFS01Z BV F12 M6

Mounting example



LSF (Pepperl & Fuchs) with MSH EPV mounting kit



GEMÜ LSC

Limit switch box for quarter turn actuators

The GEMÜ LSC limit switch box is suitable for mounting to manually and pneumatically operated quarter turn valves. It is also fitted with an optical position indicator for visual confirmation of position.

Only permissible with K-no. 7137.

Nominal size	Item no.	Designation
DN 8-20	88494998	LSCS01Z BV F04 M5
DN 25-32	88495013	LSCS01Z BV F05 M6
DN 40-50	88495019	LSCS01Z BV F07 M6
DN 65-80	88836072	LSCS01Z BV F10 M6
DN 100	88836074	LSCS01Z BV F12 M6



GEMÜ LSC

Limit switch box for quarter turn actuators

The GEMÜ LSC limit switch box is suitable for mounting to manually and pneumatically operated quarter turn valves. It is also fitted with an optical position indicator for visual confirmation of position.

Mounting example



Manual ball valve with LSC and MSH-EPV subassembly

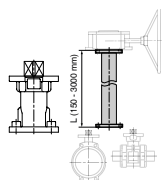

GEMÜ RC0

Shaft extension

The RC0 shaft extension for quarter turn valves is a distance piece between manually, pneumatically or electrically operated valves. This means that valves can be protected from flooding or better access for operation of the valve can be ensured (also for manual override).

Nominal size	GEMÜ RC0 shaft extension		GEMÜ AB22 and AB24 hand lever	
	Item no.	Designation	Item no.	Designation
DN 8–20	88742081	RC0VAF04 D09KF04 D09 60 M12	88658096	AB22 20D OSET
DN 25–32	88742082	RC0VAF05 D11KF05 D11 65 M14	88658097	AB22 32D OSET
DN 40–50	88742083	RC0VAF07 D14KF07 D14 80 M18	88658099	AB22 50D OSET
DN 65	88742085	RC0VAF07 D17KF07 D17100 M22	88660113	AB26 65D OSET
DN 80	88742085	RC0VAF07 D17KF07 D17100 M22	88660114	AB26 80D OSET
DN 100	88781980	RC0VAF12 D22KF12 D22 75 M28	88660420	AB24 100D OSET

Certificates

Certificate	Standard	Item number
2.2 Ferrite content measurement		88081058
2.2 Surface roughness measurement	EN10204 - EN ISO 4288	88079146
3.1 Surface roughness measurement		88094384
3.1 Material	EN 10204	88333336



GEMÜ Gebr. Müller Apparatebau GmbH & Co. KG
Fritz-Müller-Straße 6-8, 74653 Ingelfingen-Criesbach, Germany
Tel. +49 (0)7940 123-0 · info@gemue.de
www.gemu-group.com